

Intech Micro 2300-A8II analogue input station MODBUS RTU slave application supplementary manual

MODBUS supplementary manual to the 2300-A8II Installation Guide.

The 2300 series stations are designed to connect as slaves to MODBUS RTU masters such as PC's or PLC's to offer an economical I/O solution.

Intech Micro 2300 series:

- 2300-A8I : 8 Current Inputs.
- 2300-A8II : 8 Isolated Current Inputs.
- 2300-A8VI : 8 Isolated Voltage Inputs.
- 2300-Tc8 : 8 Isolated Thermocouple Inputs.
- 2300-RTD6 : 6 RTD Inputs.
- 2300-MULTI : 2 RTD, 2 AI, 1 AO, 4 DI, 2 DO.
- 2300-D16 : 16 Digital Inputs.
- 2300-RO4 : 4 Relay Outputs.



Intech Micro 2300 Series - Connection Examples.

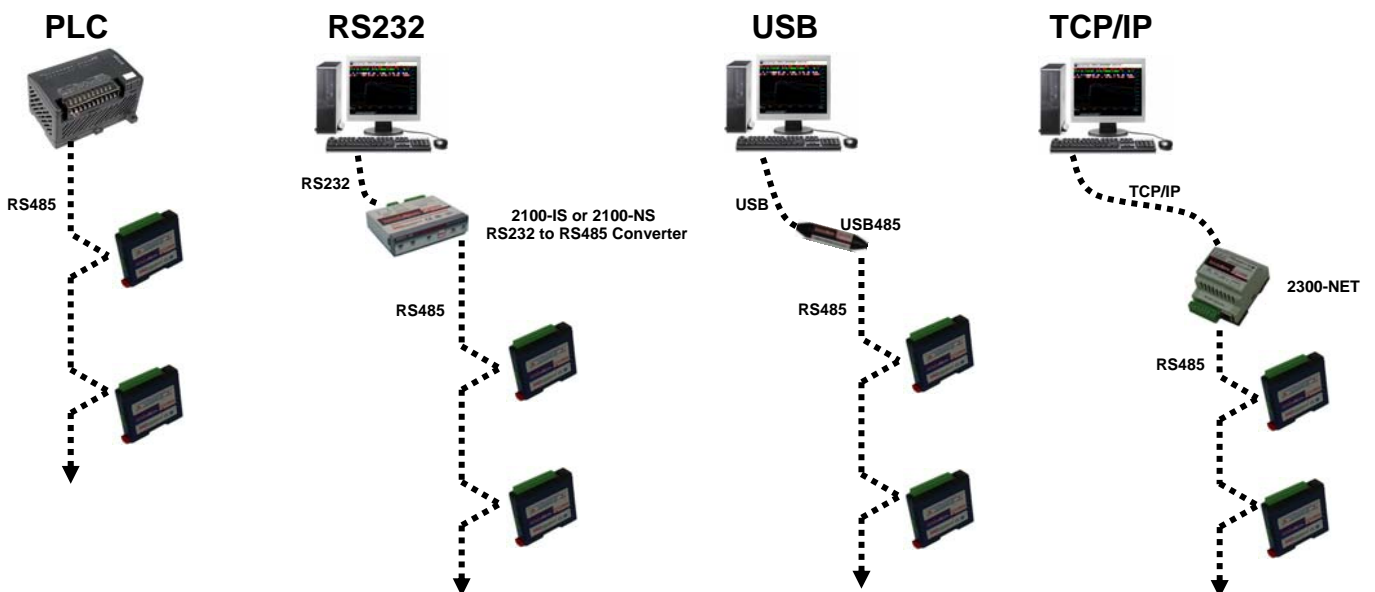

2300-A8II Specifications.

Current Inputs:	-Input Points	8	
	-Input Current	0(4)~20mA	
	-Input Type	Range	Resolution
	-1	0-4095	12 bits
	-2	0-20.000mA	1uA
	-3	+/-20.000mA	1uA
	-Drift		100ppm/°C
	-Isolation	1000Vrms between field and logic 350Vpeak between each input	
Connectors:	-Logic Power and Comms	4 Pin plug-in connector on side of station	
	-Inputs	18 Way screw plug-in connector on top of station	
Comms:	-Protocols	RS485, Modbus RTU	
	-Baud Rate	2400, 4800, 9600, 19200, 38400, 57600, 115200	
	-Format	Parity: 0 = none, 1 = even, 2 = odd Stop Bits: 1 = 1 stop bit, 2 = 2 stop bits	
Power Supply:	-Logic Supply Voltage	12~24Vdc	
	-Logic Supply Current	58mA @ 12V / 31mA @ 24V	

Safety and EMC Compliances:

EMC Compliance	89/336/EEC and Low Voltage Equipment Directive 73/23/EEC
Safety Compliance	IEC 950

General Specifications: (Unless otherwise stated in other input specifications).

Operating Temperature	-10~50°C	
Storage Temperature	-40~85°C	
Operating Humidity	Up to 95% non condensing	
Housing	-Dimensions	L=97.5, W=22.6, H=109mm
	-Mounting	35mm Symmetrical Mounting Rail.

Note 1. Contact INTECH INSTRUMENTS for more detailed programming information.

Product Liability. This information describes our products. It does not constitute guaranteed properties and is not intended to affirm the suitability of a product for a particular application. Due to ongoing research and development, designs, specifications, and documentation are subject to change without notification. Regrettably, omissions and exceptions cannot be completely ruled out. No liability will be accepted for errors, omissions or amendments to this specification. Technical data are always specified by their average values and are based on Standard Calibration Units at 25C, unless otherwise specified. Each product is subject to the 'Conditions of Sale'.

Warning: These products are not designed for use in, and should not be used for patient connected applications. In any critical installation an independent fail-safe back-up system must always be implemented.

Modbus Register Types.

There are 4 types of variables which can be accessed from the station. Each station has one or more of these data variables.

Type	Start Address	Variable	Access
1	00001	Digital Outputs	Read & Write
2	10001	Digital Inputs	Read Only
3	30001	Input registers (Analog)	Read Only
4	40001	Output registers (Analog)	Read & Write (Holding type)

Note: The Modbus message length must be limited to 100 consecutive read or write registers. If more registers are required then a new poll group must be added for the next xxx registers.

The 2300-A8II remote station has 8 isolated current inputs. The inputs are fully isolated from input to logic and between inputs. This station is ideal for monitoring existing 4~20mA current loops which are isolated from each other and cannot be connected to a common point of reference.

The standard setting for the 2300-A8II station is 0~20mA input current which represents an output value of 0 - 4095 (12 bits) in the corresponding Modbus register. To obtain an output value of 0 to 4095 for an input signal of 4 to 20mA the offset switch is switched on. This station can also be configured for a 0 – 20.000mA input range or +/- 20.000mA input.

For an input signal of 0~20mA the offset switch is switched off (see *Dip Switch Settings* on page 14.21.M-5).

Communications Settings.

The data in the stations is stored in 16 bit registers. These registers are accessed over the network using the MODBUS RTU communication protocol.

Communications Settings with DIP Switch 10 OFF (Default)

BAUD RATE 9600
 DATA BITS 8
 PARITY NONE
 STOP BITS 1

Communications Settings with DIP Switch 10 ON (Programmed Baud Rate)

BAUD RATE 2400, 4800, 9600, 19200, 38400, 57600, 115200
 DATA BITS 8
 PARITY None, Even, Odd
 STOP BITS 1, 2

Note: To change these settings, download the free MicroScan IOSTudio 2300 series MODBUS configuration software via the link from the Intech website: www.intech.co.nz/2300

During this mode, DIP Switch 10 should be OFF so that the PC can communicate with the 2300 station using the default communication settings. Once the Communications Settings are programmed, power down the 2300 station and change DIP Switch 10 to the ON position. Restore the power to the 2300 station and the configured Communications Settings will be ready for use.

Warning: Only program ONE 2300 station at a time!

Communications Settings Registers.

40121	Baud Rate	2400	11520	R/W	2400, 4800, 9600, 19200, 38400, 57600, 115200
40122	Parity	0	2	R/W	0 = none, 1 = even, 2 = odd
40123	Stop Bits	1	2	R/W	1 = 1 stop bit, 2 = 2 stop bits
40124	Reply Delay	0	65535	R/W	(x10ms)

Baud Rate Register (40121)

The baud rate value is programmed directly into the baud rate register. The only exception is the 115200 baud rate where the value 11520 is used.

Parity Register (40122)

The parity can be set to none by writing a 0 to the parity register, set to even by writing a 1 to the parity Register or set to odd by writing a 2 to the parity register.

Stop Bits Register (40123)

The number of stop bits can be set to 1 by writing a 1 to the stop bits register or set to 2 by writing a 2 to the stop bits Register.

Reply Delay Register (40124)

The reply delay is a time delay between the Modbus message received to the reply being sent. In some applications where a modem or radio is used in the RS485 network, it may be necessary to add a reply delay due to turn around delays in the equipment.

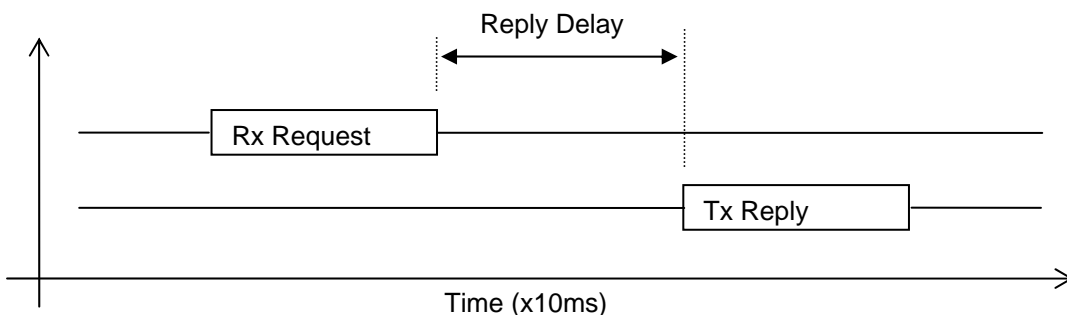

Status Indicators.

Power: Flashes to indicate the CPU is running.
RS485 Rx: Flashes to indicate the unit has received a valid Modbus message.
RS485 Tx: Flashes to indicate the unit has sent a Modbus message.
Input Status: "ON" when the input is zero.
 "OFF" when the input is greater than zero and less than 4095.
 "Flashing" when the input is over range, greater or equal to 4095

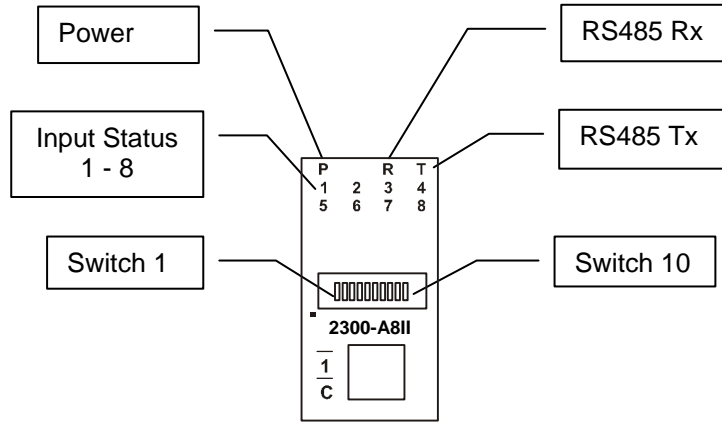

Power and RS485 Comms Wiring.

Pin	Connection
81	- } 12Vdc @ 58mA
82	+ } 24Vdc @ 31mA
71	+ } Comms
70	- } RS485

Warning: If the power/communication connections are reversed, the remote station may become faulty.

Wiring.

The following diagram shows how the analog inputs are connected to a 0(4)~20mA source. All of the common terminals are isolated from each other.

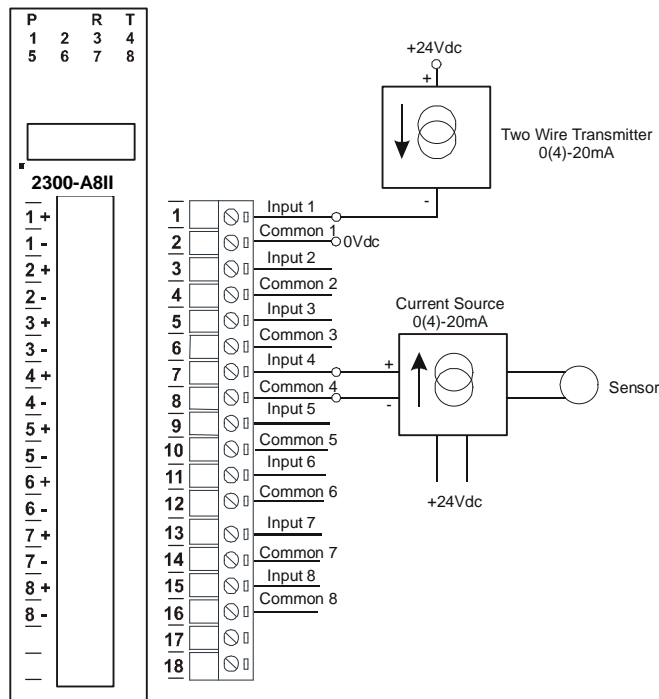

Dip Switch Settings.

DIP SWITCH	FUNCTION	DESCRIPTION
1	STATION ID +1	Station ID's from 0 to 127 are set up using switches 1 to 7
2	STATION ID +2	
3	STATION ID +4	
4	STATION ID +8	
5	STATION ID +16	
6	STATION ID +32	
7	STATION ID +64	
8	OFF SET	When switched ON the inputs are scaled to accept a 4mA offset Input break. When switched off the analog value will be loaded with -32767 when the input is faulty. When switched on the analog value will be loaded with 32768
9	BREAK	
10	BAUD RATE	Selects 9600 in off position (Default) or Programmed Baud Rate in on position

Note: See Installation Guide for the Station ID Table (Dip Switch Settings).

Data Registers.

Modbus Address	Register Name	Low Limit	High Limit	Access	Description
30001	S/W Version / Module Type	N/A	N/A	R	High Byte = Software Version Low Byte = 107
30002	Analog Input 1	0	4095	R	Analog Input lower 12 Bits
30003	Analog Input 2	0	4095	R	"
30004	Analog Input 3	0	4095	R	"
30005	Analog Input 4	0	4095	R	"
30006	Analog Input 5	0	4095	R	"
30007	Analog Input 6	0	4095	R	"
30008	Analog Input 7	0	4095	R	"
30009	Analog Input 8	0	4095	R	"
30010	Input Status	0	65535	R	bit2 = 0(open circuit or < 2), bit2 = 1(over range) bit1 = 0(OK), bit1 = 1(error)
30100	DIP Switch	0	65535	R	Status of DIP Switch on Front Panel
40121	Baud Rate	2400	11520	R/W	2400, 4800, 9600, 19200, 38400, 57600, 115200
40122	Parity	0	2	R/W	0 = none, 1 = even, 2 = odd
40123	Stop Bits	1	2	R/W	1 = 1 stop bit, 2 = 2 stop bits
40124	Reply Delay	0	65535	R/W	0 = Disable, >0 = Enable. (x10ms)

Analog Input Registers.

The analog inputs are read as a 12 bit value in the registers as follows:

MSB														2300-A8II ANALOG INPUTS														LSB				ADDRESS
15	14	13	12	11	10	9	8	7	6	5	4	3	2	1	0	15	14	13	12	11	10	9	8	7	6	5	4	3	2	1	0	
32768	16384	8192	4096	2048	1024	512	256	128	64	32	16	8	4	2	1	32768	16384	8192	4096	2048	1024	512	256	128	64	32	16	8	4	2	1	300XX

0 0 0 0 | x x x x x x x x x x x x x x x x

Analog Input: 12 Bit Value (0 - 4095)

Analog Input Status.

There are two status bits associated with each analog input. These bits are used to indicate if the input is zero or open circuit, in the working range 0-4095, or over range. If the input is open circuit or over range, then the error bit will be set. When the error bit is set, the range bit is zero if the input is open circuit and set if the input is over range, ie:

<u>Bit 1- Error</u>	<u>Bit 2-Range</u>	<u>Condition</u>	<u>Status LED</u>
0	don't care	Input working OK	(LED OFF)
1	0	Input Open circuit or zero	(LED ON)
1	1	Input Over range	(LED FLASH)

The analog input status can be read in a single register as follows:

