

LPI-F Frequency Transmitter.

Programmable Isolating Frequency
Input to 4~20mA Output
Loop Powered Transmitter.

Features.

- Field Programmable Input Ranges.
- Isolated Input to Output 2.0kV.
- Impedance Matching on Input.
- Crystal Locked F-V.
- Selectable Damping.
- High Accuracy 0.1%.
- 40~200mV Output Test Signal.
- LED Indication of Loop Current.
- Low Cost.
- Easy to Install.
- DIN Rail Mount or IP67
Water Resistant Enclosure.
- Available Standard or Special Calibration.
- Reverse Polarity Protection.



Z495

Other LPI- models include:
LPI-B :Bridge / Strain gauge;
LPI-D :DC;
LPI-K :Resistance;
LPI-N :Differential Pt100 RTD;
LPI-P :Potentiometer;
LPI-R :Pt100 RTD;
LPI-T :Thermocouple.
LPI-DO2 :DO2, LCD Display;
LPI-ORP :ORP, LCD Display;
LPI-pH :pH, LCD Display.

Ordering Information.

LPI-F-X Standard, 0~100Hz Input, Programmable
Input Range Calibration, DIN Rail Enclosure.

LPI-F- - - Special Range Special Programmable Input Range Calibration.
EN IR

ENCLOSURE OPTIONS		INPUT RANGES			
ENCLOSURE	EN	Frequency	IR	Frequency	IR
DIN Rail Mount	D	0~15Hz	1	0~1kHz	14
IP67 Wall Mount Water Resistant	E	0~20Hz	2	0~1.5kHz	15
		0~25Hz	3	0~2kHz	16
		0~40Hz	4	0~2.5kHz	17
		0~50Hz	5	0~4kHz	18
		0~75Hz	6	0~5kHz	19
		0~100Hz	7	0~7.5kHz	20
		0~150Hz	8	0~10kHz	21
		0~200Hz	9		
		0~250Hz	10		
		0~400Hz	11		
		0~500Hz	12		
		0~750Hz	13		

Ordering Examples.

LPI-F-D-8 LPI-F; DIN Rail Enclosure; 0~150Hz Input Range; Loop Powered 4~20mA Output.

LPI-F-E-3 LPI-F; IP67 Wall Mount Enclosure; 0~25Hz Input Range; Loop Powered 4~20mA Output.

Quality Assurance Programme.

The modern technology and strict procedures of the ISO9001 Quality Assurance Programme applied during design, development, production and final inspection grant the long term reliability of the instrument.

LPI-F Specifications.

Frequency Input		2 Wire Sine / Square / Pulse, Uni-polar / Bi-polar. (Signals < 2Vpp Bipolar Only.)
- Minimum Input Signal		10mVpp @ 100Hz, 100mVpp @ 1kHz, 1Vpp @ 10kHz Typical. (Offset Jumper=1 for V < 2Vpp.)
- Maximum Input Signal		100Vpp. (Offset Jumper=0 for V ≥ 2Vpp.)
- Span		Field Programmable From 15Hz to 10kHz. (100Hz Typical Max. With Debounce Jumper=1.)
		Adjustable Input Impedance From 1kΩ to 100kΩ. Open Collector Connected to + Frequency Input with 3k3 Resistor.
Output	-mA	2 wire 4~20mA. (Loop Powered.)
	-mV Test	40~200mV ±1% @ 4~20mA. Other Test Voltages Available. e.g. 1~5V. Note. mV Test Increases Power Supply & Decreases Load Resistance.
Power Supply		8~33Vdc.
Supply Voltage Sensitivity		<±0.005%/V FSO.
Output Load Resistance		800Ω @ 24Vdc. (50Ω/V Above 8Vdc.)
Maximum Output Current		Limited to <28mA.
Accurate to		<±0.1% FSO Typical.
Linearity & Repeatability		<±0.1% FSO Typical.
Ambient Drift		<±0.01%/C FSO Typical.
Noise Immunity		125dB CMRR Average. (2.0kVac RMS Limit.)
EMC Compliances		Emissions EN 55022-A. Immunity EN 50082-1, <3% Effect FSO Typical.
Isolation Test Voltages		2000Vac/dc Input to Output for 1min.
Response Time		≤1sec Typical. ≤5sec Typical with Damping On.
Operating Temperature		0~70C.
Storage Temperature		-20~80C.
Operating Humidity		5~85%RH Max. Non-Condensing.
Dimensions	-LPI-F-D	L=79, W=22.5, H=85mm.
	-LPI-F-E	L=110, W=80, H=65mm, excluding glands.

Product Liability. This information describes our products. It does not constitute guaranteed properties and is not intended to affirm the suitability of a product for a particular application. Due to ongoing research and development, designs, specifications, and documentation are subject to change without notification. Regrettably, omissions and exceptions cannot be completely ruled out. No liability will be accepted for errors, omissions or amendments to this specification. Technical data are always specified by their average values and are based on Standard Calibration Units at 25C, unless otherwise specified. Each product is subject to the 'Conditions of Sale'.

Warning: These products are not designed for use in, and should not be used for patient connected applications. In any critical installation an independent fail-safe back-up system must always be implemented.

Examples of Input Connection.

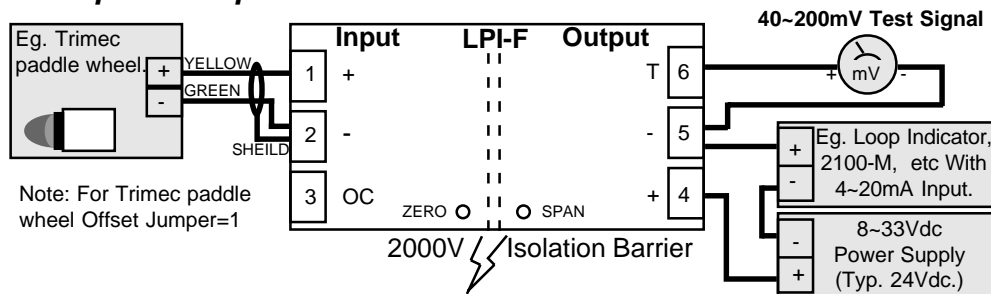

Terminations.

Input	1	+ve
	2	-ve
	3	OC
Output	4	+mA
	5	-mA
	6	mV TEST

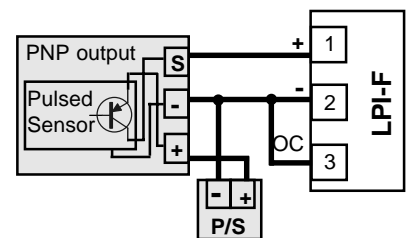
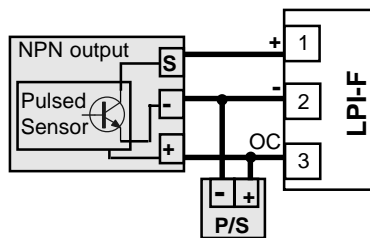
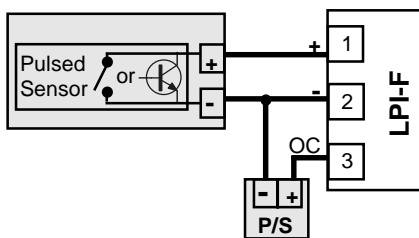

Note 1. OC = Open Collector.

Note 2. The Open Collector is internally connected to '+ Frequency Input' with a 3K3 resistor.

LPI-F Input Programming.

If the input range is not listed in the programming table, use the following formula to work out the Span DIP switch settings for gain.

$$\text{Span Gain} = \frac{60,000}{\text{FREQUENCY}}$$

Enter the Span gain value into the appropriate Span DIP switch. For the LPI-F-E DIP switches, jumpers and trimpots are accessed by removing the lid from the IP67 Water Resistant enclosure. For the LPI-F-D DIP switches, jumpers and trimpots are accessed by separating the two halves of the enclosure.

Gain Value	1	2	4	8	16	32	64	128	256	512	1024	2048
S1 Switch No.	1	2	3	4	5	6	7	8	9	10	11	12

e.g. If a gain value of 280 is required, put DIP Switch S1 - No. 4, No.5, & No.9 ON, and all the other DIP switches OFF. (i.e. Gains of 8+16+256=280)

Contact Closure Selection.

For contact closure inputs such as reed switches and relay contacts put Debounce Jumper=1. This will limit the maximum input frequency to 100Hz typical (Depending on signal type.). For particularly noisy contacts it might be necessary to place a 1µF non-polarised metal film capacitor directly across the contacts to suppress noise. Ensure the voltage rating of the capacitor is more than the voltage across the contacts. (Minimum of 16V.)

Voltage Input Range Selection.

Note: The low voltage option is only available for bipolar signals. (Signals that move either side of 0V.)
 For low voltage input signals < 2Vpp (eg. from a paddle wheel) the Offset Jumper=1.
 For voltage input signals ≥ 2Vpp Offset Jumper=0.

Impedance Matching.

For noisy inputs use the trimpot marked 'P1' to tune the input impedance to equal the source impedance. To do this:
 (i) install and commission transmitter as described on the following page;
 (ii) slowly turn the trimpot anticlockwise, until the output becomes steady.

Damping Selection.

For increased damping or an input frequency of ≤50Hz put Damping Jumper=1. This increases damping to 5sec typical.

LPI-F Input Range Programming Table.

Notes: Switch Status 1 = ON, 0 = OFF.

INPUT FREQUENCY	S1-SPAN												Damping Jumper
	1	2	3	4	5	6	7	8	9	10	11	12	
0~15Hz	0	0	0	0	0	1	0	1	1	1	1	1	1
0~20Hz	0	0	0	1	1	1	0	1	1	1	0	1	1
0~25Hz	0	0	0	0	0	1	1	0	1	0	0	1	1
0~40Hz	0	0	1	1	1	0	1	1	1	0	1	0	1
0~50Hz	0	0	0	0	1	1	0	1	0	0	1	0	1
0~75Hz	0	0	0	0	0	1	0	0	1	1	0	0	0
0~100Hz	0	0	0	1	1	0	1	0	0	1	0	0	0
0~150Hz	0	0	0	0	1	0	0	1	1	0	0	0	0
0~200Hz	0	0	1	1	0	1	0	0	1	0	0	0	0
0~250Hz	0	0	0	0	1	1	1	1	0	0	0	0	0
0~400Hz	0	1	1	0	1	0	0	1	0	0	0	0	0
0~500Hz	0	0	0	1	1	1	1	0	0	0	0	0	0
0~750Hz	0	0	0	0	1	0	1	0	0	0	0	0	0
0~1kHz	0	0	1	1	1	1	0	0	0	0	0	0	0
0~1.5kHz	0	0	0	1	0	1	0	0	0	0	0	0	0
0~2kHz	0	1	1	1	1	0	0	0	0	0	0	0	0
0~2.5kHz	0	0	0	1	1	0	0	0	0	0	0	0	0
0~4kHz	1	1	1	1	0	0	0	0	0	0	0	0	0
0~5kHz	0	0	1	1	0	0	0	0	0	0	0	0	0
0~7.5kHz	0	0	0	1	0	0	0	0	0	0	0	0	0
0~10kHz	0	1	1	0	0	0	0	0	0	0	0	0	0

LPI-F-D Enclosure Dimensions.

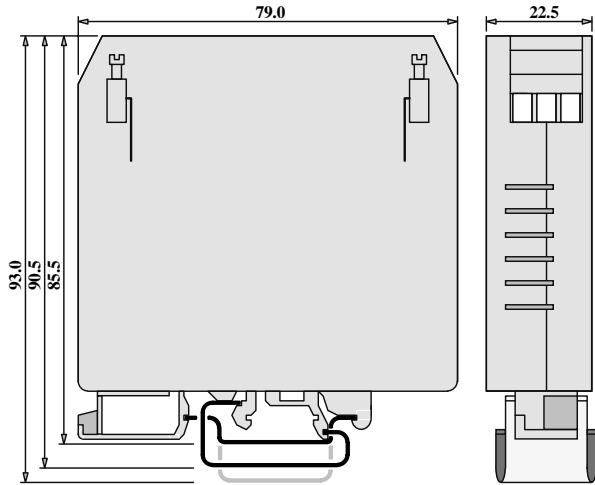

LPI-F-E Enclosure Dimensions.

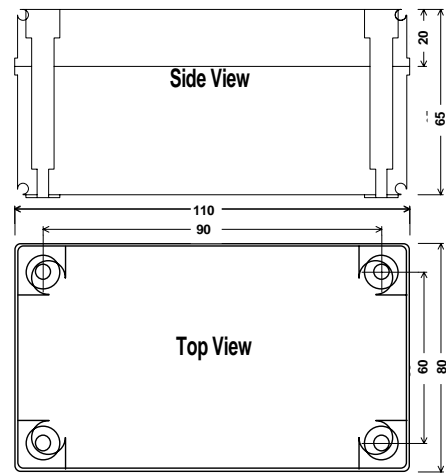

Maximum Load Vs Power Supply.

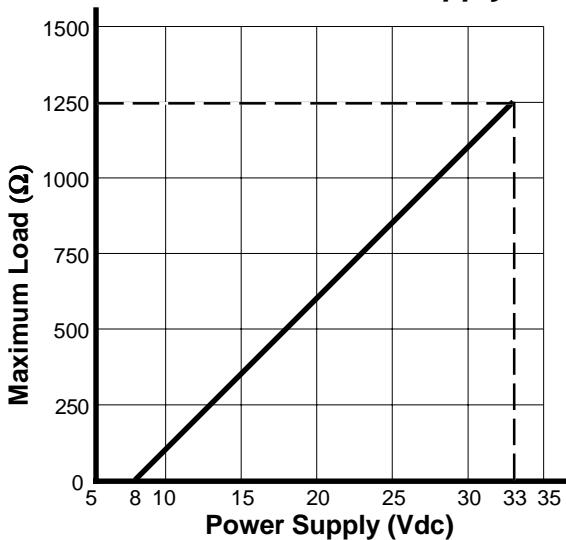

Plan View of LPI-F Adjustments.

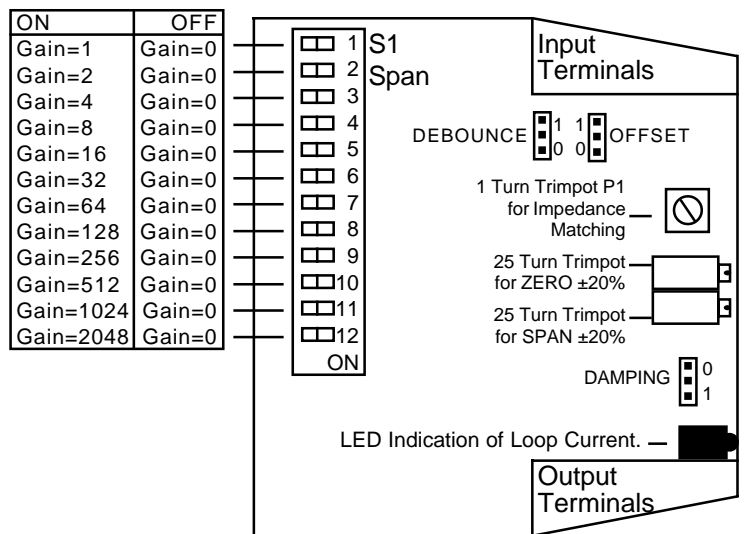

The Proper Installation & Maintenance of LPI-F.

All power and signals must be de-energised before connecting any wiring, or altering any Jumpers or Dip Switches.

- MOUNTING.**
- (1) Mount in a clean environment in an electrical cabinet on DIN or EN mounting rail.
 - (2) Draft holes must have minimum free air space of 20mm. Foreign matter must not enter or block draft holes.
 - (3) Do not subject to vibration or excess temperature or humidity variations.
 - (4) Avoid mounting in cabinets with power control equipment.
 - (5) To maintain compliance with the EMC Directives the LPI-B is to be mounted in a fully enclosed steel cabinet. The cabinet must be properly earthed, with appropriate input / output entry points and cabling.

- WIRING.**
- (1) All cables should be good quality overall screened INSTRUMENTATION CABLE with the screen earthed at one end only.
 - (2) Signal cables should be laid a minimum distance of 300mm from any power cables.
 - (3) For 2 wire current loops and 2 wire voltage signals or 2 wire current signals, Austral Standard Cables B5102ES is recommended. For 3 wire transmitters Austral Standard Cables B5103ES is recommended.
 - (4) It is recommended that you do not ground current loops and use power supplies with ungrounded outputs.
 - (5) Lightning arrestors should be used when there is a danger from this source.
 - (6) Refer to diagrams for connection information.

- COMMISSIONING.**
- (1) Once all the above conditions have been carried out and the wiring checked apply power to the LPI-F loop and allow five minutes for it to stabilize.
 - (2) If the output of the transmitter is fluctuating, follow the procedures outlined in 'Input Programming; Contact Closure Selection', 'Voltage Input Range Selection', 'Impedance Matching', and 'Damping Selection'.
 - (3) Take a low (approx. 10%) and a high (approx. 90%) reading of the variable being measured by the transducer supplying the signal to the LPI-F, and ensure that this agrees with the level being indicated by the PLC, indicator, etc. the LPI-F is connected into. Adjust for any difference using the Zero and Span Pots in the LPI-F with a small screw driver until the two levels agree. (Clockwise to increase the output reading and anti-clockwise to decrease the output reading.)

- MAINTENANCE.**
- (1) Repeat (3) of COMMISSIONING.
 - (2) Do it regularly - at least once every 12 months.

Intech INSTRUMENTS LTD
www.intech.co.nz
 Christchurch Ph: +64 3 343 0646
 Central Ph: 06 876 0034
 Auckland Ph: 09 827 1930
 Email: sales@intech.co.nz