

LPI-P Potentiometer Transmitter.

Isolating 3 Wire Potentiometer
Input to 4~20mA Output
Loop Powered Transmitter.

Features.

- Field Programmable Input Ranges.
- Isolated Input to Output 2.0kV.
- High Accuracy.
- 40~200mV Output Test Signal.
- LED Indication of Loop Current.
- Selectable 3 Second Damping.
- Low Cost.
- Easy to Install.
- Compact DIN Rail Mount Enclosure.
- Available Standard or Special Calibration.
- Reverse Polarity Protection.



Other LPI- models include:
LPI-B :Bridge / Strain gauge;
LPI-D :DC;
LPI-F :Frequency;
LPI-K :Resistance;
LPI-N :Differential Pt100 RTD;
LPI-R :Pt100 RTD;
LPI-T :Thermocouple;
LPI-DO2 :DO2, LCD Display;
LPI-ORP :ORP, LCD Display;
LPI-pH :pH, LCD Display.

Ordering Information.

LPI-P-X Standard 0~100% Input; Programmable Input Range; Calibration.

LPI-P - -Special Range Special Programmable Input Range Calibration.
IR

INPUT RANGE (% of POTENTIOMETER.)			
%POT	IR	%POT	IR
0~10%	1	20~40%	16
0~15%	2	40~60%	17
0~20%	3	60~80%	18
0~25%	4	80~100%	19
0~30%	5	25~50%	20
0~33%	6	50~75%	21
0~40%	7	75~100%	22
0~50%	8	33~67%	23
0~60%	9	67~100%	24
0~67%	10	50~100%	25
0~70%	11	10~90%	26
0~75%	12	20~80%	27
0~80%	13	25~75%	28
0~90%	14	30~70%	29
0~100%	15	40~80%	30
Special Input Calibration Range			Z

Ordering Examples.

LPI-P-8 LPI-P; 0~50% Input; Loop Powered 4~20mA Output.

LPI-P-26 LPI-P; 10~90% Input; Loop Powered 4~20mA Output.

Quality Assurance Programme.

The modern technology and strict procedures of the ISO9001 Quality Assurance Programme applied during design, development, production and final inspection grant the long term reliability of the instrument.

LPI-P Specifications.

Potentiometer Input		3 Wire Potentiometer. Excitation = 0.25V. Minimum Potentiometer Resistance = 1k Ω . Maximum Potentiometer Resistance = 1M Ω . Field Programmable Zero From 0 to 100%. Field Programmable Span From 0 to 100%.
	-Damping	3 Second Selectable with H1.
Output	-mA	2 wire 4~20mA. (Loop Powered.)
	-mV Test	40~200mV \pm 1% @ 4~20mA. Other Test Voltages Available. e.g. 1~5V. Note. mV Test Increases Power Supply & Decreases Load Resistance.
Power Supply		8~33Vdc.
Supply Voltage Sensitivity		< \pm 0.005%/V FSO.
Output Load Resistance		800 Ω @ 24Vdc. (50 Ω /V Above 8Vdc.)
Maximum Output Current		Limited to <28mA.
Accurate to		< \pm 0.1% FSO Typical.
Linearity & Repeatability		< \pm 0.1% FSO Typical.
Ambient Drift		< \pm 0.02%/C FSO Typical.
Noise Immunity		125dB CMRR Average. (2.0KVac RMS Limit.)
EMC Compliances		Emissions EN 55022-A. Immunity EN 50082-1, <1% Effect FSO Typical.
Isolation Test Voltages		2000Vac/dc Input to Output for 1min.
Response Time		200msec Typical. (10 to 90% 50msec Typical.)
Operating Temperature		0~70C.
Storage Temperature		-20~80C.
Operating Humidity		5~85%RH Max. Non-Condensing.
Dimensions and Construction		L=79, W=22.5, H=85mm. Polyamide Thermoplastic Rail Mount Enclosure.

Product Liability. This information describes our products. It does not constitute guaranteed properties and is not intended to affirm the suitability of a product for a particular application. Due to ongoing research and development, designs, specifications, and documentation are subject to change without notification. Regrettably, omissions and exceptions cannot be completely ruled out. No liability will be accepted for errors, omissions or amendments to this specification. Technical data are always specified by their average values and are based on Standard Calibration Units at 25C, unless otherwise specified. Each product is subject to the 'Conditions of Sale'.

Warning: These products are not designed for use in, and should not be used for patient connected applications. In any critical installation an independent fail-safe back-up system must always be implemented.

Examples of Input Connection.

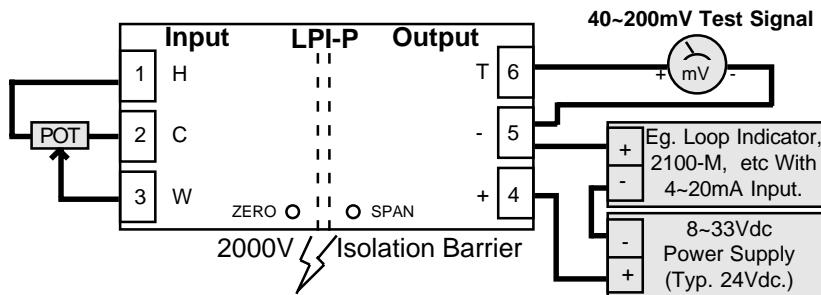

Terminations.

Input	1	HIGH
	2	COM
	3	WIPER
Output	4	+mA
	5	-mA
	6	mV TEST

Enclosure Dimensions.

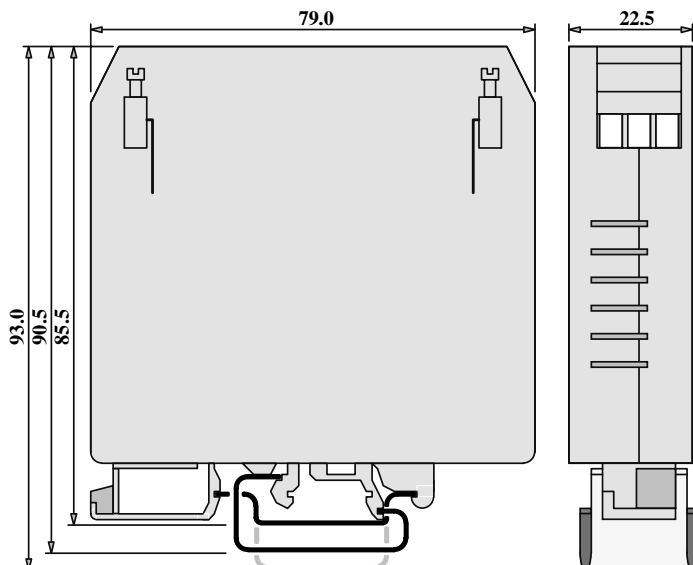

Maximum Load Vs Power Supply.

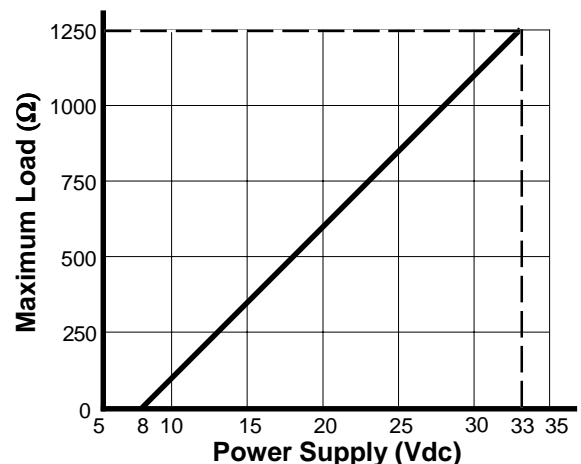

LPI-P Input Programming.

If the input range is not listed in the programming table, use the following formulae to work out the Zero and Span DIP switch settings for gain.

$$\text{Span Gain} = \frac{600}{\text{POT\% High} - \text{POT\% Low}}$$

$$\text{Zero Gain} = \frac{\text{POT\% Low}}{2}$$

Enter the Zero or Span gain value into the appropriate Zero or Span DIP switch.

Gain Value	1	2	4	8	16	32
DIP Switch No.	1	2	3	4	5	6

So if a gain value of 28 is required, put DIP switch No's 3, 4, 5 OFF (ie, gains of 4 + 8 + 16 = 28) and all the other DIP switches ON. Dip switches are accessed by separating the two halves of the LPI-P enclosure

LPI-P Input Range Programming Table.

- Notes: 1/ Switch status 1 = ON, 0 = OFF, X = DON'T CARE.
 2/ Input ranges with '*' beside them require more adjustment by the Zero & Span trimpots.

INPUT RANGE % of POT.	S1-ZERO						S2-SPAN					
	1	2	3	4	5	6	1	2	3	4	5	6
0~10%	1	1	1	1	1	1	1	1	0	0	0	0
0~15%	1	1	1	1	1	1	1	1	1	0	1	0
0~20%	1	1	1	1	1	1	1	0	0	0	0	1
0~25%	1	1	1	1	1	1	1	1	1	0	0	1
0~30%	1	1	1	1	1	1	1	1	0	1	0	1
0~33%	1	1	1	1	1	1	1	1	0	1	1	0
0~40%	1	1	1	1	1	1	1	0	0	0	0	1
0~50%	1	1	1	1	1	1	1	1	1	0	0	1
0~60%	1	1	1	1	1	1	1	1	0	1	0	1
0~67%	1	1	1	1	1	1	1	0	1	1	0	1
0~70% *	1	1	1	1	1	1	1	0	1	1	0	1
0~75%	1	1	1	1	1	1	1	1	1	1	0	1
0~80% *	1	1	1	1	1	1	1	1	1	1	0	1
0~90% *	1	1	1	1	1	1	1	0	0	0	1	1
0~100%	1	1	1	1	1	1	1	1	0	0	1	1
20~40%	1	0	1	0	1	1	1	1	0	0	0	1
40~60%	1	1	0	1	0	1	1	1	0	0	0	1
60~80%	1	0	0	0	0	1	1	1	0	0	0	1
80~100%	1	1	1	0	1	0	1	1	0	0	0	1
25~50% *	0	1	0	0	1	1	1	1	1	1	0	1
50~75%	0	1	1	0	0	1	1	1	1	1	0	1
75~100%	1	0	0	1	1	0	1	1	1	1	0	1
33~67% *	0	1	1	1	0	1	1	1	0	1	1	0
67~100%	1	0	1	1	1	0	1	1	0	1	1	0
50~100%	0	1	1	0	0	1	1	1	1	0	0	1
10~90% *	0	1	0	1	1	1	1	1	1	1	0	1
20~80%	1	0	1	0	1	1	1	1	0	1	0	1
25~75% *	0	1	0	0	1	1	1	1	1	0	0	1
30~70%	0	0	0	0	1	1	1	0	0	0	1	1
40~80%	1	1	0	1	0	1	1	0	0	0	1	1

Plan View of LPI-P Adjustments.

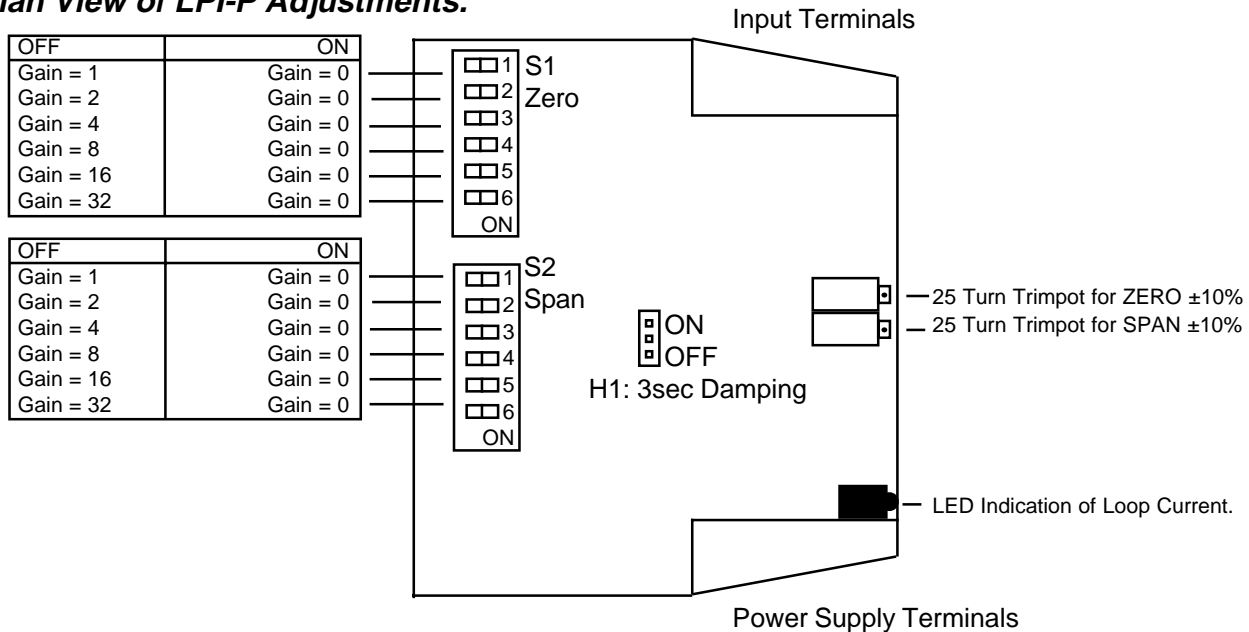

The Proper Installation & Maintenance of LPI-P.

All power and signals must be de-energised before connecting any wiring, or altering any Jumpers or Dip Switches.

MOUNTING.

- (1) Mount in a clean environment in an electrical cabinet on DIN or EN mounting rail.
- (2) Draft holes must have minimum free air space of 20mm. Foreign matter must not enter or block draft holes.
- (3) Do not subject to vibration or excess temperature or humidity variations.
- (4) Avoid mounting in cabinets with power control equipment.
- (5) To maintain compliance with the EMC Directives the LPI-B is to be mounted in a fully enclosed steel cabinet. The cabinet must be properly earthed, with appropriate input / output entry points and cabling.

WIRING.

- (1) All cables should be good quality overall screened INSTRUMENTATION CABLE with the screen earthed at one end only.
- (2) Signal cables should be laid a minimum distance of 300mm from any power cables.
- (3) For 2 wire current loops and 2 wire voltage signals or 2 wire current signals, Austral Standard Cables B5102ES is recommended. For 3 wire transmitters, RTDs, resistance probes, and potentiometers Austral Standard Cables B5103ES is recommended.
- (4) It is recommended that you do not ground current loops and use power supplies with ungrounded outputs.
- (5) Lightning arrestors should be used when there is a danger from this source.
- (6) Refer to diagrams for connection information.

COMMISSIONING.

- (1) Once all the above conditions have been carried out and the wiring checked apply power to the LPI-P loop and allow five minutes for it to stabilize.
- (2) Due to cable resistance and errors within the potentiometer itself a small error may occur (usually less than 1%). To remove this error adjust the Zero and Span trim pots in the top of the LPI-P enclosure with a small screwdriver. (Clockwise to increase the output reading & Anticlockwise to decrease the output reading)
- (3) Take a low (approx 10%) and high (approx 90%) reading of the variable being measured by the transducer supplying the signal to the LPI-P, and ensure that this agrees with the level being indicated by the PLC or indicator, etc, that the LPI-P is connected into. Adjust for any difference using the Zero and Span Pots in the top of the LPI-P enclosure.

MAINTENANCE.

- (1) Repeat (3) of Commissioning.
- (2) Do it regularly - at least once every 12 months.

Intech INSTRUMENTS LTD
www.intech.co.nz
 Christchurch Ph: +64 3 343 0646
 Central Ph: 06 876 0034
 Auckland Ph: 09 827 1930
 Email: sales@intech.co.nz