

LPI-T Thermocouple Transmitter.

Isolating Thermocouple Input
to 4~20mA Output
Loop Powered Transmitter.

Features.

- Available for Types J, K, N, R, S, T.
- Field Programmable Input Ranges.
- Output Linear with Temperature.
- Internal Cold Junction Compensation.
- Isolated Input to Output 2.0kV.
- High Accuracy.
- 40~200mV Output Test Signal.
- LED Indication of Loop Current.
- Low Cost.
- Easy to Install.
- Compact DIN Rail Mount Enclosure.
- Available Standard or Special Calibration.
- Reverse Polarity Protection.



Other LPI- models include:
LPI-B :Bridge / Strain gauge;
LPI-D :DC;
LPI-F :Frequency;
LPI-K :Resistance;
LPI-N :Differential Pt100 RTD;
LPI-P :Potentiometer;
LPI-R :Pt100 RTD;
LPI-DO2 :DO2, LCD Display;
LPI-pH :pH, LCD Display;
LPI-ORP :ORP, LCD Display;

Ordering Information.

LPI-T-F-X Standard; Type K 0~1200C; Upscale; Fixed Input Range Calibration.

LPI-T-F- ---Special Range Special Fixed Input Range Calibration.
TT IR SB

LPI-T-P-X Standard; Type K 0~1200C; Upscale; Programmable Input Range Calibration.

LPI-T-P- ---Special Range Special Programmable Input Range Calibration.
TT IR SB

THERMOCOUPLE TYPE		INPUT TEMPERATURE RANGES								SENSOR BREAK		
Max Range	TT	deg C	IR	deg C	IR	deg F	IR	deg F	IR	State	SB	
0~800C	J	0~100	1	-50~50	17	0~200	41	-100~100	57	Upscale	US	
0~1500F	J	0~125	2	-100~0	18	0~250	42	-200~0	58	Downscale	DS	
		0~150	3	-100~100	19	0~300	43	-200~200	59			
0~1200C	K	0~200	4	-100~200	20	0~400	44	-200~400	60			
0~2200F	K	0~250	5	50~150	21	0~500	45	100~300	61			
		0~300	6	100~200	22	0~600	46	200~400	62			
0~1200C	N	0~400	7	200~400	23	0~800	47	400~800	63			
0~2200F	N	0~500	8	200~600	24	0~1000	48	400~1200	64			
		0~600	9	400~800	25	0~1200	49	800~1600	65			
0~1700C	R	0~750	10	400~1200	26	0~1500	50	800~2400	66			
0~3100F	R	0~800	11	400~1600	27	0~1600	51	800~3200	67			
		0~1000	12	500~800	28	0~2000	52	1000~1600	68			
0~1700C	S	0~1200	13	500~1000	29	0~2400	53	1000~2000	69			
0~3100F	S	0~1400	14	600~1200	30	0~2800	54	1000~2400	70			
		0~1600	15	600~1600	31	0~3000	55	1200~3000	71			
-100~200C	T	0~1700	16	1000~1700	32	0~3200	56	1200~3200	72			
-150~400F	T											
		Special Input Range								Z		

Ordering Examples.

LPI-T-P-K-7 LPI-T; Programmable; Type K; 0~400C In; Upscale Break; Loop Powered; 4~20mA Output.

LPI-T-F-R-55-DS LPI-T; Fixed Range; Type R; 0~3000F In; Downscale Break; Loop Powered; 4~20mA Output.

Quality Assurance Programme.

The modern technology and strict procedures of the ISO9001 Quality Assurance Programme applied during design, development, production and final inspection grant the long term reliability of the instrument.

LPI-T Specifications.

Input

Note 1: The input range must be within the specified **min / max range** of the thermocouple type.

Note 2: Each LPI-T is only rangeable within the specified 'Thermocouple Type'.

Type	Thermocouple Type		Field Programmable Input Ranges								Linearity and Accuracy: %, ±1C (±2F)
	Specification Range (C)	Specification Range (F)	Zero Offset				Span (Max. In - Zero)				
			Min.(C)	Max.(C)	Min.(F)	Max.(F)	Min.(C)	Max.(C)	Min.(F)	Max.(F)	
J	0-800	0-1500	0	600	0	1100	200	800	400	1500	0.25
K	0-1200	0-2200	0	1000	0	1800	200	1200	400	2200	0.25
N	0-1200	0-2200	0	1000	0	1800	200	1200	400	2200	0.25
R	400-1700	750-3100	0	1300	0	2400	400	1700	750	3100	0.5
S	400-1700	750-3100	0	1300	0	2400	400	1700	750	3100	0.5
T	-100-200	-150-400	-100	100	-150	200	100	300	200	550	0.5

- Impedances	Input Impedance = 1MΩ Min. Thermocouple Lead Resistance = 100Ω Max.
CJC Accuracy	<0.03C/C (0.06F/F) Typical.
Output	2 wire 4~20mA. (Loop Powered.)
-mA	40~200mV ±1% @ 4~20mA. Other Test Voltages Available. e.g. 1~5V.
-mV Test	Note. mV Test Increases Power Supply & Decreases Load Resistance.
Power Supply	8~33Vdc.
Supply Voltage Sensitivity	<±0.005%/V FSO.
Output Load Resistance	800Ω @ 24Vdc. (50Ω/V Above 8Vdc.)
Maximum Output Current	Limited to <28mA.
Sensor Fail	-Upscale 23mA Min. -Downscale 3.8mA Max.
Repeatability	<±0.1% FSO Typical.
Ambient Drift	<±0.02%/C FSO Typical.
Noise Immunity	125dB CMRR Average. (2.0kVac RMS Limit.)
EMC Compliances	Emissions EN 55022-A. Immunity EN 50082-1, <1% Effect FSO Typical.
Isolation Test Voltages	2000Vac/dc Input to Output for 1min.
Response Time	200msec Typical. (10 to 90% 50msec Typical.)
Operating Temperature	0~70C.
Storage Temperature	-20~80C.
Operating Humidity	5~85%RH Max. Non-Condensing.
Dimensions and Construction	L=79, W=22.5, H=85mm. Polyamide Thermoplastic Rail Mount.

Product Liability. This information describes our products. It does not constitute guaranteed properties and is not intended to affirm the suitability of a product for a particular application. Due to ongoing research and development, designs, specifications, and documentation are subject to change without notification. Regrettably, omissions and exceptions cannot be completely ruled out. No liability will be accepted for errors, omissions or amendments to this specification. Technical data are always specified by their average values and are based on Standard Calibration Units at 25C, unless otherwise specified. Each product is subject to the 'Conditions of Sale'.

Warning: These products are not designed for use in, and should not be used for patient connected applications. In any critical installation an independent fail-safe back-up system must always be implemented.

Examples of Input Connection.

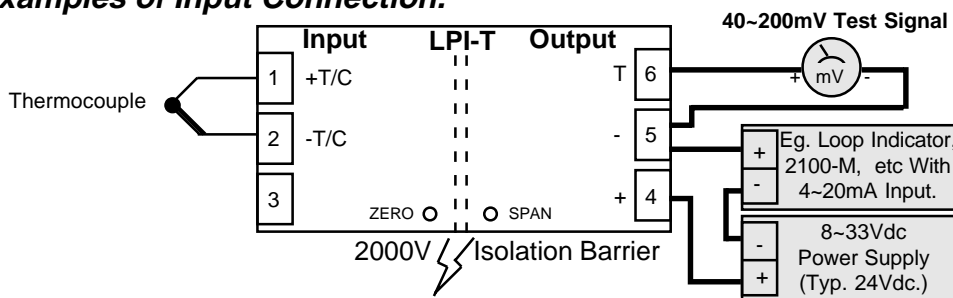

Terminations.

Input	1	+T/C
	2	-T/C
	3	
Output	4	+mA
	5	-mA
	6	mV TEST

Enclosure Dimensions.

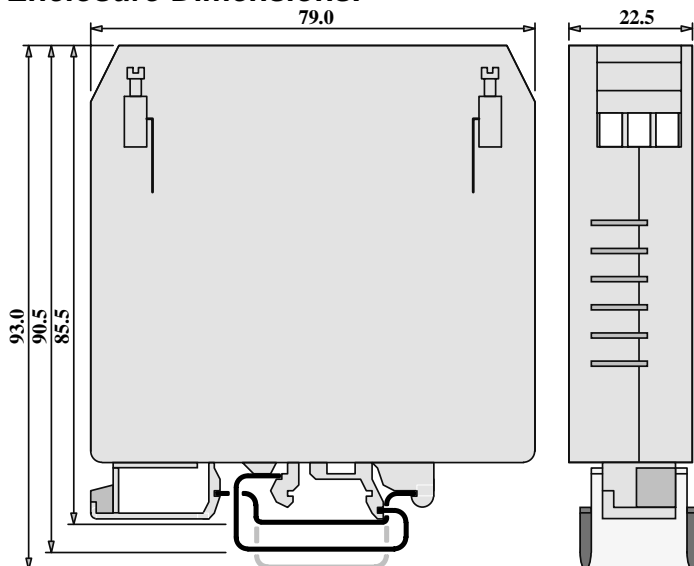

Maximum Load Vs Power Supply.

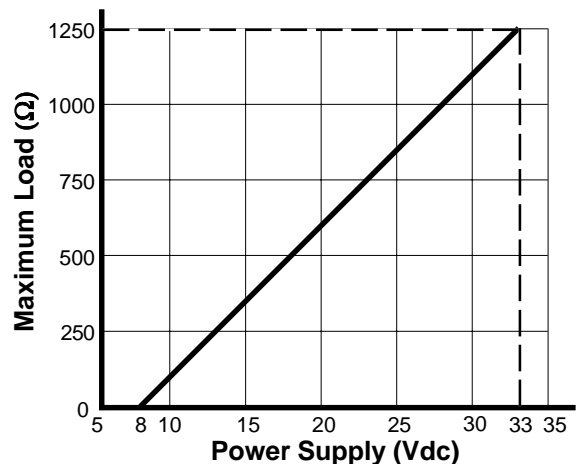

Plan View of LPI-T-P Adjustments.

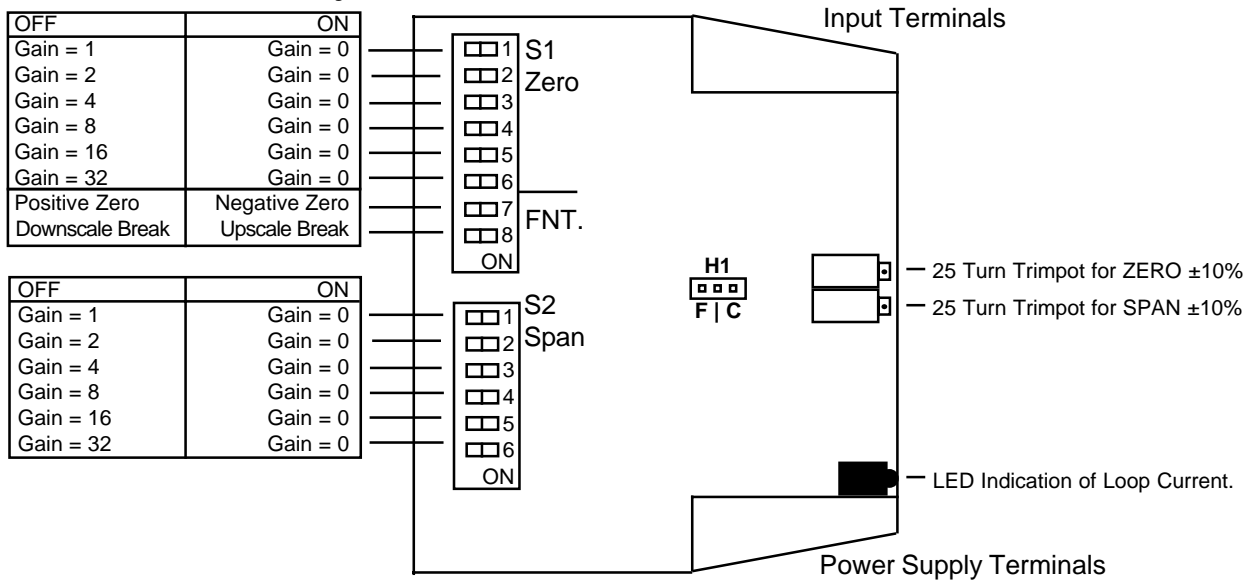

The Proper Installation & Maintenance of LPI-T.

All power and signals must be de-energised before connecting any wiring, or altering any Jumpers or Dip Switches.

MOUNTING

- (1) Mount in a clean environment in an electrical cabinet on DIN or EN mounting rail.
- (2) Draft holes must have minimum free air space of 20mm. Foreign matter must not enter or block draft holes.
- (3) Do not subject to vibration or excess temperature or humidity variations.
- (4) Avoid mounting in cabinets with power control equipment.
- (5) To maintain compliance with the EMC Directives the LPI-B is to be mounted in a fully enclosed steel cabinet. The cabinet must be properly earthed, with appropriate input / output entry points and cabling.

WIRING

- (1) All cables should be good quality overall screened INSTRUMENTATION CABLE with the screen earthed at one end only.
- (2) Signal cables should be laid a minimum distance of 300mm from any power cable.
- (3) For 2 wire current loops Austral Standard Cables B5102ES is recommended.
- (4) It is recommended that you do not ground current loops and use power supplies with ungrounded outputs.
- (5) Lightning arresters should be used when there is a danger from this source.
- (6) Refer to diagrams for connection information.

THERMOCOUPLES.

- (1) Avoid locating the thermocouple where it will be in a direct flame.
- (2) Never insert a porcelain or refractory tube suddenly in a hot area. Pre-heat gradually while installing.
- (3) Locate it where the average temperature will be measured. It should be representative of the mass. If necessary use several thermocouples to obtain the average temperature.
- (4) Immerse the thermocouple far enough so that the measuring junction is entirely in the temperature to be measured: nine to ten times the diameter of the protection tube is recommended. Heat that is conducted away from the junction causes an error in reading.
- (5) If the thermocouple is mounted horizontally and the temperature is above the softening point of the tube, a support should be provided to prevent the tube sagging. Otherwise install the tube vertically.
- (6) Keep the junction head and cold junction in the approximation of the ambient temperature. Especially in the Noble Metal Class.

EXTENSION WIRE.

- (1) Use the correct thermocouple extension or compensation cable. i.e. Thermocouple type, insulation type, correct colour coding.
- (2) If possible install extension or compensation cable in a grounded conduit by themselves. Never run electrical wires in the same conduit.
- (3) All wires that must be spliced should be soldered, or a proper thermocouple termination block used.
- (4) Lightning arresters should be used where there is a danger from this source.

COMMISSIONING

- (1) Once all the above conditions have been carried out and the wiring checked apply power to the LPI-T loop and allow five minutes for it to stabilize.
- (2) Due to the limits of error in a standard thermocouple probe, and standard extension wire and compensating wire, an error can occur. For example in a type K thermocouple installation an error of 2.2C or 0.75% FSO (whichever is greater) can occur. To check the variable being measured use a calibration standard thermocouple at the same immersion depth and adjust the Zero Pot in the top of the LPI-T enclosure with a small screwdriver, until the two levels agree.

MAINTENANCE

- (1) Check thermocouples in place with a calibration thermocouple at the same immersion depth.
- (2) Do it regularly - at least once a month.
- (3) Replace defective protection tubes - even if they look good they may not be air or gas tight.
- (4) Check out extension cable circuits.

Intech INSTRUMENTS LTD
www.intech.co.nz
 Christchurch Ph: +64 3 343 0646
 Central Ph: 06 876 0034
 Auckland Ph: 09 827 1930
 Email: sales@intech.co.nz