

# LPN-H Humidity and Temperature Transmitter.

The LPN-H has two independent, 2 wire, 4~20mA loop powered outputs:  
One for relative Humidity;  
One for Temperature.

## Features.

- Dual 4~20mA Outputs.
- Monolithic IC Humidity Sensor.
- %RH Temperature Compensated Linear Output.
- Pt100 RTD Sensor.
- Temperature Output 0~100C. (0~200F Optional)
- Temperature Output Linearised.
- Very Compact Design.
- High Accuracy.
- Low Cost.
- Easy to Install.
- Reverse Polarity Protection.
- Internally Accessible Span & Zero Adjustments.
- Wide Power Supply Range.



## Description.

The LPN-H is a complete relative humidity and temperature sensing module, with two independent loop powered 4~20mA output signals, representing 0~100%RH and 0~100C.

Two versions are available:

- (i) Wall mount.
- (ii) Duct mount.

Both versions come complete in an industry standard aluminium connection head. The relative humidity sensor and temperature compensating sensor protrude from the head inside a protective cap. This cap allows air to circulate to the sensors.

## Reliability.

The wide operating range of the humidity and temperature sensors offer long term reliability over a broad range of applications. The sensors resist contaminating vapours such as organic solvents, chlorine, and ammonia.

## Ordering Information.

MODEL: <b>LPN-H-D</b>	220mm Duct Mount, 0~100%RH Transmitter, 0~100C Transmitter.
<b>LPN-H-W</b>	Wall Mount, 0~100%RH Transmitter, 0~100C Transmitter.
<b>LPN-H-F</b>	100mm Flange for LPN-H-D

Note: 0~200F temperature output optional. Please specify when ordering.

## Quality Assurance Programme.

The modern technology and strict procedures of the ISO9001 Quality Assurance Programme applied during design, development, production and final inspection grant the long term reliability of the instrument.

### LPN-H %RH Transmitter Specifications.

Accurate to	±2% FSO Typical. 0~100%RH @ 25C Saturated Salt Calibration.
Important:	For continuous measurements of ≥90%RH, refer to note 2 below.
Ambient Temperature Drift	<±0.05%/C FSO Typical.
Humidity Sensor -Hysteresis	±0.8% of Span Typical.
-Linearity	±0.5%RH Typical.
-Repeatability	±0.5%RH Typical.
-Long Term Drift	±1%RH Typical at 50%RH in 5 years.

### LPN-H Temperature Transmitter Specifications.

Accurate to	<±0.1% FSO Typical.
Linearity and Repeatability	<±0.1% FSO Typical.
Ambient Temperature Drift	<±0.02%/C FSO Typical.
RTD Sensor	Pt100 RTD, Class A Din 43760.
Sensor Current	0.5mA.

### LPN-H Common Specifications.

Output.	2 wire 4~20mA (Loop Powered).
Power Supply.	9~33Vdc.
Supply Voltage Sensitivity.	<±0.01%/V FSO.
Maximum Output Current.	Limited to <36mA.
Output Load Resistance.	750Ω @ 24Vdc. (50Ω/V Above 9Vdc).
EMC Compliances	Emissions EN 55022-A. Immunity EN 50082-1, <1% Effect FSO Typ.
Isolation Test Voltage	Between %RH and Temperature; 50Vdc for 1 min.
Operating Temperature.	-at head <sup>A)</sup> 0~70C. -at sensor <sup>B)</sup> -30~85C (LPN-H-D)
Storage Temperature.	-30~85C.
Operating Humidity.	-at head <sup>A)</sup> 5~85%RH Max. Non-condensing. -at sensor <sup>B)</sup> 0~100%RH. Refer note 4 below.

Note: <sup>A)</sup> 'at head' refers to ratings for electronics housed in the connection head.

<sup>B)</sup> 'at sensor' refers to ratings for electronics housed in the protective cap.

Note 1. Good airflow and good air mixing must be maintained over the sensor to minimise local temperature fluctuations, and to ensure accurate measurements.

Note 2. The RH sensors quickly recover from condensation or wetting. However, after 24 hours or longer exposures to either high >90%RH or continuous condensation, an upward shift of 2% to 3%RH may occur. This shift is repeatable and can be reversed by placing the sensor in a low 10%RH environment for a 10 hour period.

CONDENSATION occurs whenever the surface temperature of the sensor's active area drops below the ambient dew point of the surrounding gas. Condensation forms on the sensor (or any surface) even if the surface temperature only momentarily drops below the ambient dew point. Small temperature fluctuations near the sensor can unknowingly cause condensation to form when operating at humidity levels above 90%.

While quick to condense, water is slow to evaporate in high humidity conditions. (ie when the surface temperature of the sensor is only slightly above the ambient dew point.) Because of this, a sensor's recovery from either condensation or wetting is much longer than its normal time response. During recovery, the sensor outputs a constant 100%RH signal, regardless of the ambient RH.

**Product Liability.** This information describes our products. It does not constitute guaranteed properties and is not intended to affirm the suitability of a product for a particular application. Due to ongoing research and development, designs, specifications, and documentation are subject to change without notification. Regrettably, omissions and exceptions cannot be completely ruled out. No liability will be accepted for errors, omissions or amendments to this specification. Technical data are always specified by their average values and are based on Standard Calibration Units at 25C, unless otherwise specified. Each product is subject to the 'Conditions of Sale'.

**Warning: These products are not designed for use in, and should not be used for patient connected applications. In any critical installation an independant fail-safe back-up system must always be implemented.**

### LPN-H-W Dimensions.

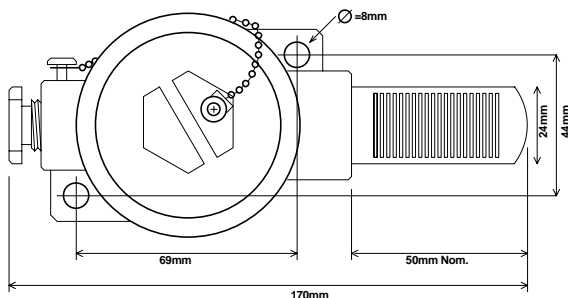

### LPN-H-F Dimensions.

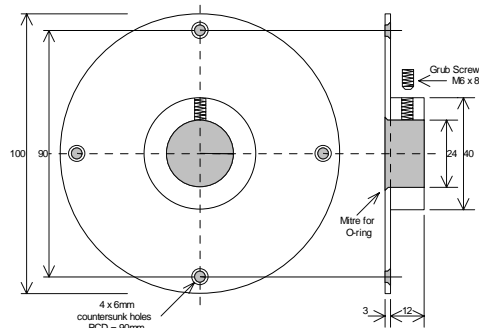

### LPN-H-D Dimensions.

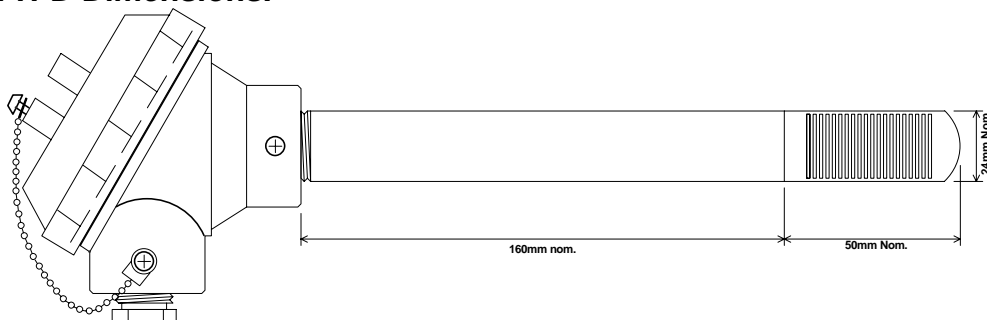

**LPN-H Terminals and Layout.**

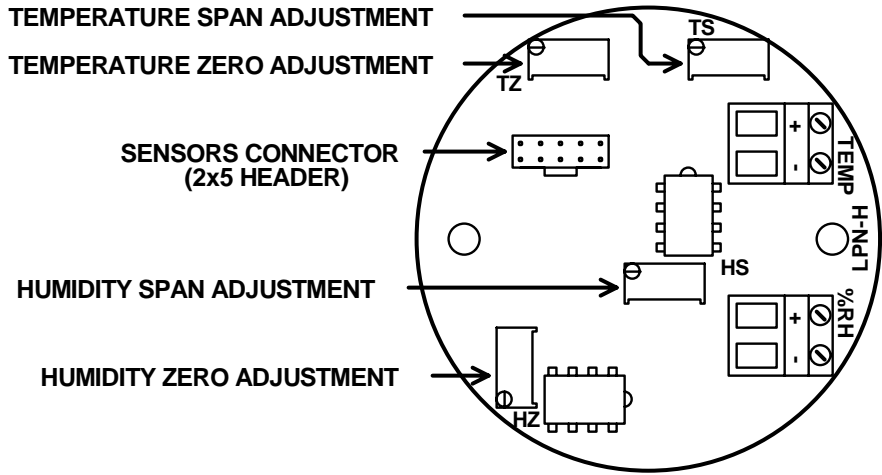

**Graph Of Maximum Load Versus Power Supply.**

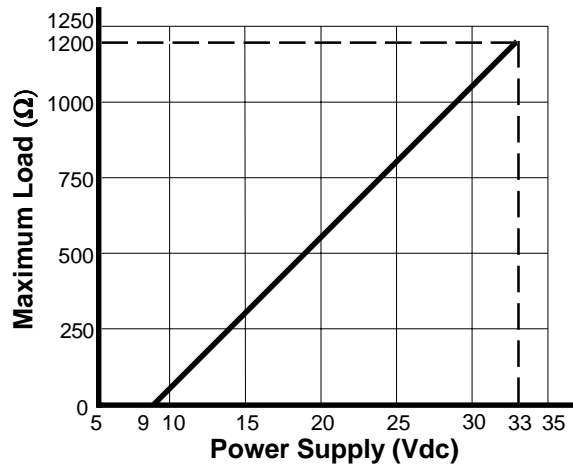

**LPN-H Connection Example.**

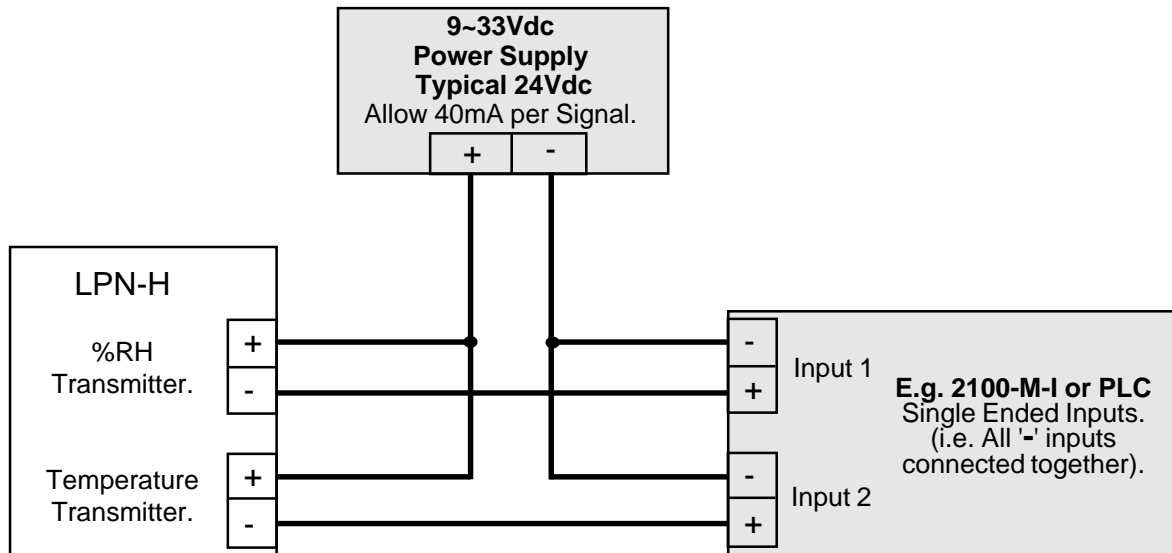

## The Proper Installation & Maintenance of LPN-H.

All power and signals must be de-energised before connecting any wiring, or altering any Jumpers or Dip Switches.

### MOUNTING.

- (1) Mount in a clean environment.
- (2) Do not subject to vibration.
- (3) Avoid mounting near power control equipment.
- (4) Mount the LPN-H-W on a solid wall or panel, where air will flow freely around it.
- (5) Mount the LPN-H-D through a LPN-H-F 100mm flange, into the duct.
- (6) Always mount the LPN-H so that the protective cap is either horizontal or sloping downwards. This helps prevent condensate build up in high humidity situations.
- (7) Avoid mounting where the protective cap will get wet as this may cause false readings.
- (8) Again ensure there is adequate air flow over the sensor.
- (9) To maintain compliance with the EMC Directives, the LPN-H metal enclosure must be properly earthed, with appropriate input / output entry points, cabling and filtering.

### WIRING.

- (1) All cables should be good quality overall screened INSTRUMENTATION CABLE with the screen earthed at one end only.
- (2) Signal cables should be laid a minimum distance of 300mm from any power cables.
- (3) For the two, 2 wire current loops Austral Standard Cables B5002CS is recommended.
- (4) It is recommended that you do not ground current loops and use power supplies with ungrounded outputs.
- (5) Lightning arrestors should be used when there is a danger from this source.
- (6) Refer to diagrams for connection information.

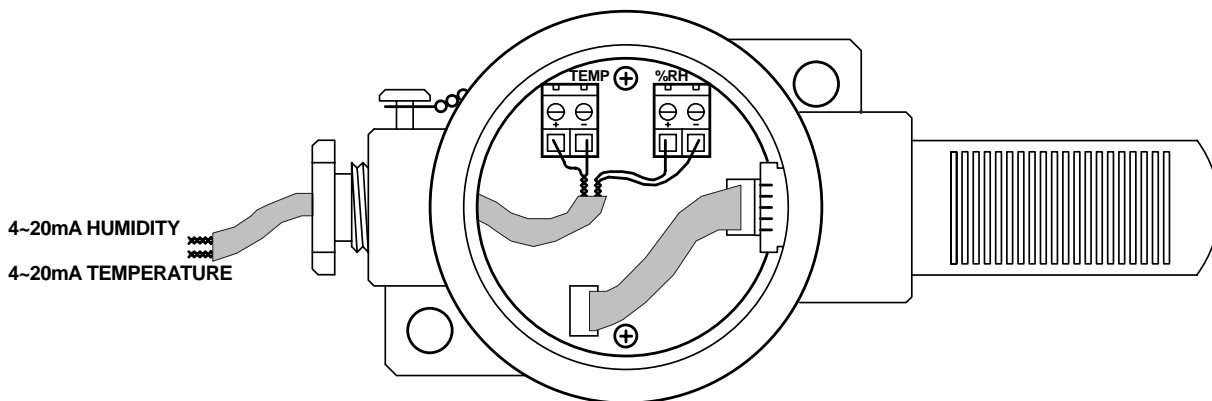

### COMMISSIONING.

- (1) Once all the above conditions have been carried out and the wiring checked apply power to the LPN-H loops and allow five minutes for them to stabilize.
- (2) To check humidity accuracy use a calibration standard %RH device in the same location. Check that the readings agree within 2% + % error of the calibration device. Alternatively expose the LPN-H to a known %RH atmosphere, and check the readings agree within 2% + % error of atmosphere.  
All readings should be referenced against the ASTM Relative Humidity tables, and allowances made for pressure effects if necessary. Any differences can be corrected using the Humidity Zero and Span Pots on the LPN-H. (Clockwise to increase the output reading, and anticlockwise to decrease the output readings.)
- (3) To check temperature accuracy use a calibration standard RTD in the same location. Check that the readings agree within 0.1% of the calibration device. Any differences can be corrected using the Temperature Zero and Span Pots on the LPN-H. (Clockwise to increase the output reading, (and anticlockwise to decrease the output readings.)

### MAINTENANCE.

- (1) Repeat 2 and 3 of Commissioning - breathing on the protective cap will cause the %RH and Temperature readings to alter.
- (2) Do it regularly - at least once every 6 months.
- (3) Check cables entering the LPN-H head.

### CLEANING OR REPLACING THE PROTECTIVE CAP.

If the protective cap becomes dirty it can easily be removed for cleaning, or replaced, as follows:

- (1) Disconnect power from LPN-H.
- (2) Carefully unscrew the cap by hand. No tools to be used - they may damage the protective cap.
- (3) The cap may now be cleaned or replaced.
- (4) Ensure the cap is thoroughly dry before replacing.
- (5) Carefully screw the cap back on by hand, and reapply the power to the LPN-H

NOTE: The LPN-H must not be operated without the protective cap, as the humidity sensor reading is affected by light.

**Intech** INSTRUMENTS LTD  
[www.intech.co.nz](http://www.intech.co.nz)  
Christchurch Ph: +64 3 343 0646  
Central Ph: 06 876 0034  
Auckland Ph: 09 827 1930  
Email: [sales@intech.co.nz](mailto:sales@intech.co.nz)