

Ordering Information

XU Demo Kit



ITEM	CODE	DESCRIPTION
SERIES	XU-KIT	XU Demo Box - Which Includes: XU2HI, XU2HN, XU2, XU4 and XU-USB.



XU2HI & XU2HN, Head Mount Isolated & Non-Isolated Transmitters



ITEM	CODE	DESCRIPTION
SERIES	XU2HI- XU2HN-	Head Mount Transmitter Isolated Head Mount Transmitter Non-Isolated*
Type of Input	Pt100- Pt1000- Tc □ -	RTD Pt100 DIN (Options JIS & CN10) RTD Pt1000 DIN (Options JIS & CN10) Thermocouple Type; B, E, J, K, N, R, S, T
Measuring Range	-	State Measuring Range
Output Action on Sensor Fail	US DS	Upscale Downscale

Note: Thermocouple I/P is not recommended on Non-Isolated Transmitters* unless care is taken with system design.

XU2, 2 Wire Transmitter Loop Powered



ITEM	CODE	DESCRIPTION
SERIES	XU2-	Universal Input Transmitter
Type of Input	Pt100- Pt1000- Tc □ - mA- mV- V- Pot 1- Pot 2-	RTD Pt100 DIN (Options JIS & CN10) RTD Pt1000 DIN (Options JIS & CN10) Thermocouple Type; B, E, J, K, N, R, S, T mA Input impedance = 10Ω mV Input resistance = 300KΩ V Input resistance = 300KΩ Potentiometer Low = 0~2KΩ Potentiometer High = 0~1MΩ
Measuring Range	-	State Measuring Range
Output Action on Sensor Fail	US DS	Upscale Downscale

Ordering Examples:

- 1/ XU2 - Pt100 - 0~100C - DS XU2; RTD Pt100 DIN 0~100°C Input; Downscale; 4~20mA Output.
2/ XU2 - Tc K - 0~1200C - US XU2; Thermocouple Type K 0~1200°C Input; Upscale; 4~20mA Output.



XU4, 4 Wire Universal Transmitter

ITEM	CODE	DESCRIPTION
SERIES	XU4-	4 Wire Universal Input Transmitter
Type of Input	Pt100- Pt1000- Tc □ - mA- mV- V- Pot 1- Pot 2-	RTD Pt100 DIN (Options JIS & CN10) RTD Pt1000 DIN (Options JIS & CN10) Thermocouple Type; B, E, J, K, N, R, S, T mA Input impedance = 10Ω mV Input resistance = 300KΩ V Input resistance = 300KΩ Potentiometer Low = 1K~2KΩ Potentiometer High = 5K~1MΩ
Measuring Range	-	State Measuring Range
Type and Range of Output	-	State Current Output Range (e.g. 4~20mA) or State Voltage Output Range (e.g. 0~10V)
Output Action on Sensor Fail	US DS	Upscale Downscale

Ordering Examples:

- 1/ XU4 - Pt100 - 0~100C - 0~10V - DS XU4; RTD Pt100 DIN 0~100°C Input; Voltage: 0~10V Output; Downscale.
2/ XU4 - Tc K - 0~1200C - 4~20mA - US XU4; Thermocouple Type K 0~1200°C Input; 4~20mA Output; Upscale.

XU-USB USB Programming Key

Download free XU programming software via the link online:

www.intech.co.nz/xu-usb



Phone: 1-800-49-VESPO or 1-239-348-8086
Fax: 1-800-36-VESPO or 1-239-348-9910

controls@vespo.com

>> www.vespo.com



XU Transmitter Series

XU2

2 Wire Transmitter
Loop Powered



Isolated

XU2HI & XU2HN

In Head 2 wire
Loop Powered



Isolated & Non Isolated

XU4

4 Wire Universal
Transmitter



Isolated

Power Supply:
20~265Vac &
21~265Vdc

Common Features

- Programmable via USB.
- No power supply or calibration required during programming.
- Input types:
 - Thermocouple B, E, J, K, N, R, S, T
 - RTD Pt100 and Pt1000
 - mA, V, & mV *
 - Potentiometer *
 - 32 point curve fitter for mA, mV, V inputs.*
 - * Not available in the XU2HI / XU2HN.
- Input to Output Isolation 3750Vac. (Excluding XU2HN)
- High Accuracy 0.1%.
- Reverse Polarity Protected.
- Heartbeat Status LED. (Excluding XU2HN)
- Case Temperature range -20°C to +80°C.
- Compact DIN Rail Mount Enclosure.
- Easy to Install.
- Low Cost.



★ Zero Adjust
Potentiometer
(Excluding XU2HN)

★ No power supply or calibration
required during programming!

XU2, XU2HI & XU2HN (2 Wire) Universal Input

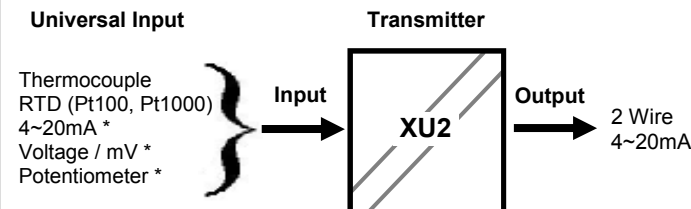

* Not available in the XU2HI / XU2HN.

XU4 (4 Wire) Universal Input

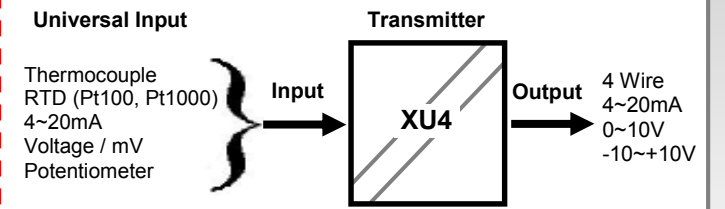

Product Liability. This information describes our products. It does not constitute guaranteed properties and is not intended to affirm the suitability of a product for a particular application. Due to ongoing research and development, designs, specifications, and documentation are subject to change without notification. Regrettably, omissions and exceptions cannot be completely ruled out. No liability will be accepted for errors, omissions or amendments to this specification. Technical data are always specified by their average values and are based on Standard Calibration Units at 25C, unless otherwise specified. Each product is subject to the 'Conditions of Sale'.

Warning: These products are not designed for use in, and should not be used for patient connected applications. In any critical installation an independent fail-safe back-up system must always be implemented



controls@vespo.com

>> www.vespo.com

XU2, XU2HI & XU2HN Specifications

Output	2 wire 4~20mA / or 20~4mA - Loop Powered.
Power Supply	9.5~36Vdc.
Supply Voltage Sensitivity	<±0.005%/V FSO.
Output Load Resistance	700Ω @ 24Vdc. (50Ω/V Above 9.5Vdc.)
Maximum Output Current	Limited to <28mA.
EMC Emissions Compliance	EN 61326
EMC Immunity Compliance	EN 61326
Safety Compliance	EN 61010-1
Accurate to	<±0.03% FSO Typical.
Linearity & Repeatability	<±0.02% FSO Typical. (Unless Individual Specifications State Otherwise)
Ambient Drift	<±0.003%/C FSO Typical.
Noise Immunity	125dB CMRR Average. (2.0k Vdc Limit.)
R.F. Immunity	<1% Effect FSO Typical.
Signal Isolation Voltage	Between Input and Output 3750Vac for 1 min. (Excluding XU2HN)
Response Time	400msec Typical. (From 10 to 90% 300msec Typical.)
Sensor Fail	Low 3.8mA, High 21mA
Startup Time	3 seconds, 3.7mA output
Output calibrate via Pot	±0.5mA Zero offset adjust. (Excluding XU2HN)
Operating Temperature	-20~85°C (XU2HN: -20~55°C)
Storage Temperature	-20~100°C
Operating Humidity	5~85%RH Max. Non-Condensing.
Mounting	35mm Symmetrical Mounting Rail. In Head mount for XU2HI & XU2HN
Dimensions	XU2: H=79, W=20, D=68mm. / XU2HI & XU2HN: H=44, W=44, D=23mm.

XU4 Specifications

Output	4 wire
- Voltage	Field Programmable from 0V-10V, 10V-0V, +10Vto(-10V), -10V to +10V
- Current	Field Programmable from 4~20mA, 0~20mA, 20~4mA & 20~0mA
Maximum Output Drive	Maximum Output Drive = 10.4Vdc. (520Ω@20mA.)
Maximum Output Drive	Maximum Output Drive = 20mA (650Ω maximum load @13Vdc.)
Universal P/S:	20~265Vac and 21~265Vdc
- Circuit Sensitivity	<±0.001%/V FSO Typical.
EMC Emissions Compliance	EN 61326
EMC Immunity Compliance	EN 61326
Safety Compliance	EN 61010-1
Accurate to	<±0.03% FSO Typical.
Linearity & Repeatability	<±0.02% FSO Typical. (Unless Individual Specifications State Otherwise.)
Ambient Drift	<±0.003%/C FSO Typical.
Noise Immunity	125dB CMRR Average. (2.0kVdc Limit.)
R.F. Immunity	<1% Effect FSO Typical.
Signal Isolation Voltage	Between Input and Output 3750Vac for 1 min.
Response Time	400msec Typical. (From 10 to 90% 300msec Typical)
Error Detection	LED indication for sensor errors.
Operating Temperature	-20~85°C.
Storage Temperature	-20~100°C.
Operating Humidity	5~85%RH Max. Non-Condensing.
Mounting	35mm Symmetrical Mounting Rail.
Dimensions	H=79, W=30, D=68mm.

Terminal Connections

XU2HI

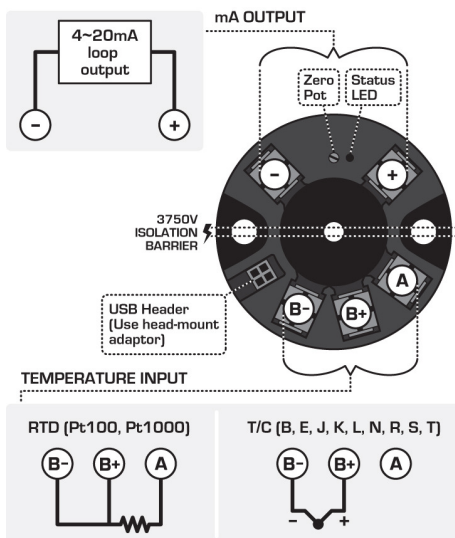

XU2HN

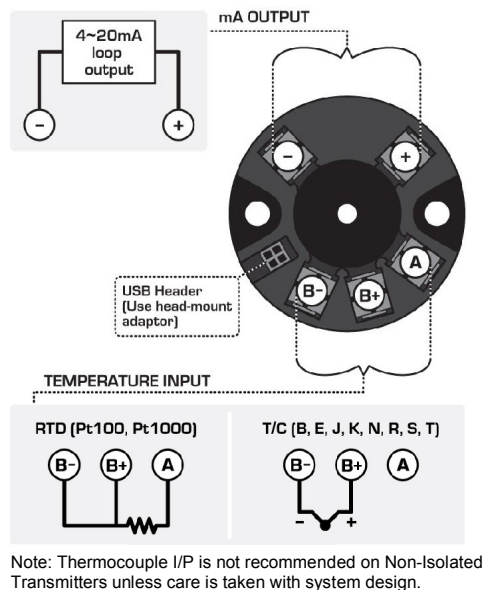

XU2

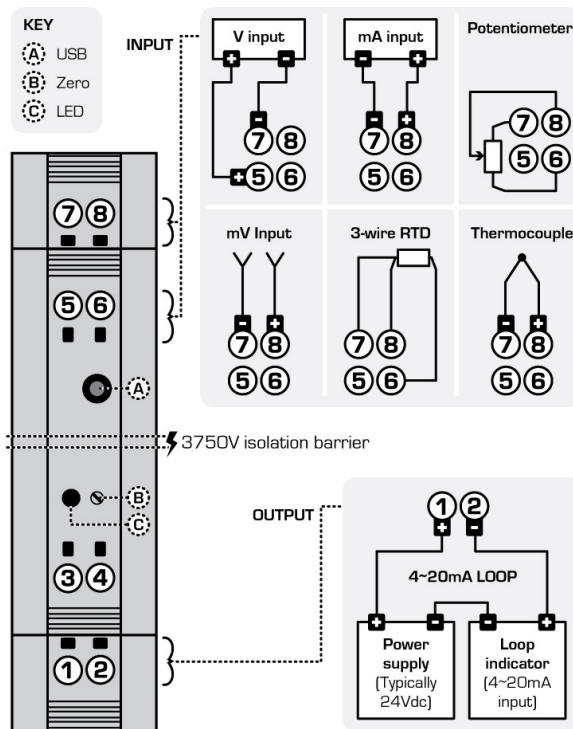

XU4

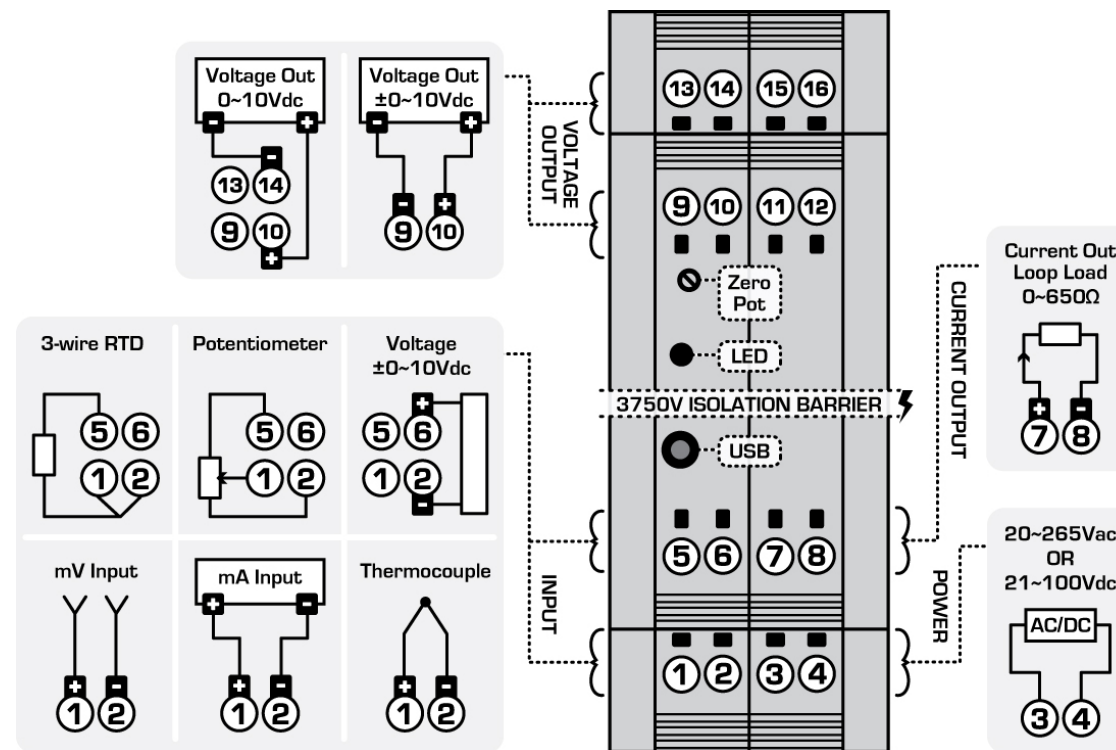

Common Specifications

Thermocouple

Thermocouple Input	Types B, E, J, K, N, R, S, T
- USB Programmable Zero	From 0 to ±99% of the Span.
- USB Programmable Span	Within Thermocouple Type Limits.
- Input Impedance	1MΩ Minimum.
- T/C Lead Resistance	100Ω Maximum.
- Cold Junction Comp. Range	-20~90°C.
- Accuracy	- E, J, K, N, T <±1°C, temp drift <±0.05°C - B, R, S <±2°C, temp drift <±0.2°C
- CJC error	<±1°C
- Output Linear with temperature	
- Sensor Break Output Drive	Upscale Standard. Downscale selectable.

RTD

RTD Input	Pt100 or Pt1000 DIN 3 Wire Type. (2 Wire can be used with offset Calibration)
- Sensor Current	0.15mA Nominal
- Lead Wire Resistance	Pt100: 10Ω/Wire Max. Pt1000: 5Ω/Wire Max. 0.02%FSO Offset error per Ω of lead resistance.
- USB Programmable Zero	From 0 to ±99% of the Span.
- USB Programmable Span	From -200C to 850°C
- Sensor Break Output Drive	Funct High Upscale. Funct Low Downscale
- Linearity (Pt100)	0.02% FSO for SPAN Inputs ≤200°C. 0.1% FSO for SPAN Inputs ≤850°C.
- Linearity (Pt1000)	0.02% FSO for SPAN Inputs ≤200°C. 0.2% FSO for SPAN Inputs ≤520°C.
<i>Other Types of RTD Available.</i>	JIS and CN10

Voltage/Current Input

Voltage Input	
- USB Programmable Zero	From 0 to ±99% of the Span.
- USB Programmable Span	From ±100mVdc to ±10Vdc and Bipolar.
- Minimum Input Resistance	300kΩ.
- mV Maximum Over-range	3Vdc Continuous.
- V Maximum Over-range	60Vdc Continuous
- Linearity Repeatability	<±0.02% FSO Typical
WARNING: Do NOT apply a V input greater than 3V to mV terminals!	
Current Input	
- USB Programmable Zero	From 0 to ±99% of the Span.
- Field Programmable Span	From 1μA to 24mAdc. Standard range = 4~20mA
- Minimum Recommended Span	0~1mA (gives 1000 steps on output)
- Input Resistance	10Ω.
- Maximum Over-range	50mAdc Continuous.
- Linearity and Repeatability	<±0.02% FSO Typical

Potentiometer

Potentiometer Input	3 Wire Potentiometer.
- Excitation Voltage	1.2Vdc.
- Potentiometer Resistance	Low Range 1KΩ~2KΩ.
- Maximum Pot Resistance	High Range 5KΩ~1MΩ.
- USB Programmable Zero	From 0 to 90% of the Span.
- Field Programmable Span	From 0.1 to 100%.
- Linearity and Repeatability	<±0.02% FSO Typical