



Weather **SENSOR** TRANSMITTERS

4~20mA Environmental Monitoring Probe Sets
Anemometer (Wind Speed)

Wind Vane

Light Energy Sensor (Pyranometer)

Solar Radiation Shield — Model THP-CL

Humidity Sensor

Temperature Sensor

Weather Sensors Transmitters — Mounting Methods

>> www.vespo.com

4~20mA Environmental Monitoring Probe Sets

Intech Instruments Ltd has a range of Weather Sensor Transmitters available which use the industry standard 4~20mA output signal (loop powered). This allows for easy integration into a SCADA or PLC monitoring system.

Weather Sensor Transmitters are tools for the observation and recording of meteorological data. The sensors can monitor air temperature, humidity, barometric pressure, light energy, wind speed and wind direction.

Wind Direction, Wind Speed and Light Energy Options

Ordering Information for Fully Mounted systems:

Note: All sensors have a 4~20mA output signal (loop powered).
Sensors can also be ordered individually.

WS3-WD-TB-CL	Wind speed 3 cup, wind direction, mounted on T bar Mounting Arm c/w 5m cable
WS3-WD-LE-TB-CL	Wind speed 3 cup, wind direction, light energy, mounted on T bar Mounting Arm c/w 5m cable

Options

WS6	Fit WS6 (Wind speed 6 cup), instead of WS3 on above T bar options (used for lower starting speeds)
THP-CL	Temperature and Humidity, both housed in Solar Radiation Shield c/w 5m cable on the above T bar options

More information on the sensors and the equipment Mounting Arm is on the pages following > >



**Wind Speed
(3 cup Anemometer)**

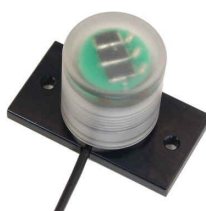

Light Energy



Wind Direction



**Temperature /
Relative Humidity / Barometric Pressure
(housed in Solar Radiation shield)**

Anemometer (Wind Speed)

The **Anemometer** is used for the measurement of wind velocity. The TruTrack Anemometer is manufactured from stainless steel and anodized aluminium so as to provide minimum maintenance and maximum reliability.

Three Cup Anemometer specifications:

- Range 0~55 m/s
- Accuracy $\pm 2\%$
- Start Speed 1.5 m/s



The Anemometer can be supplied with a 4 to 20mA Output or Pulse (switch closure).

4 to 20mA output is:

4mA at 0 metres/second

20mA at 60 metres/second

Pulse Output is 2 pulses per metre

The Anemometer is supplied attached to the T Bar Equipment Mounting Arm (shown left). Options are available to supply free standing (as above) or on a base mounting plate for attaching to posts or buildings.

We also have a six cup Anemometer available if your application requires lower starting speeds (= 0.45 m/s).

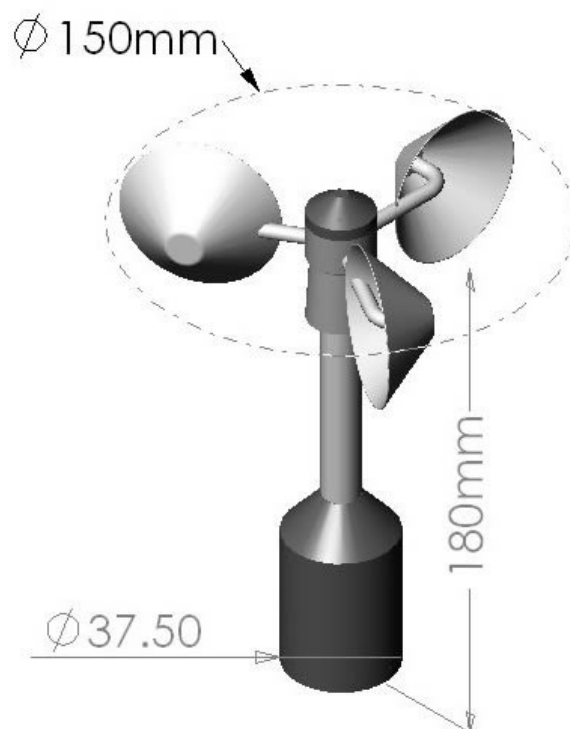

Wind Vane

The **Wind Vane** is manufactured from stainless steel and anodized aluminium so as to provide minimum maintenance and maximum reliability.

- Range 0°~360°
- Accuracy $\pm 5^\circ$
- Dead band 20° (350°~10°)

The Wind Direction Vane has a 4 to 20mA output.

4 to 20mA output is:

- 4mA at 0 deg North
- 12mA at 180deg South
- 20mA at 360 deg North

The Wind Direction Vane is supplied attached to the T Bar Equipment Mounting Arm. Options are available to supply free standing (as shown above) or on a base mounting plate for attaching to posts or buildings.

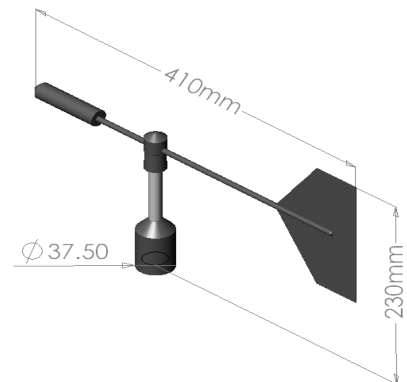
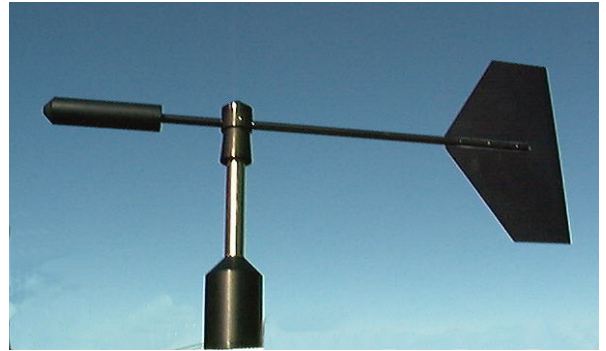

Light Energy Sensor (Pyranometer)

The **Light Energy Sensor** (Pyranometer) has been designed to provide a wide spectral response, a good cosine response and low susceptibility to inaccuracies caused by rain drop and dirt effects.

- Range 0~1500 w/m²
- Accuracy $\pm 5\%$
- Cosine error is typically less than 3% from vertical to 85° in all directions
- Temperature Coefficient 0.15% per 1°C

The Light Energy Sensor is supplied attached to a T Bar Equipment Mounting Arm. Options are available to supply free standing, or on a Base Mounting Plate as shown on above.

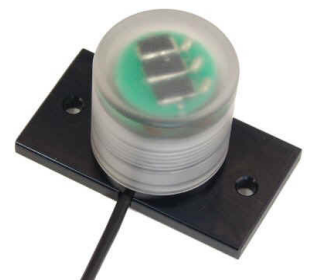

The **Pyranometer** uses an polycrystalline silicon solar cell to measure the incoming global solar radiation. This gives good accuracy without the expense and maintenance required by a Thermopile Pyranometer. It also provides a flatter spectral response than the photo diodes that are frequently used for this type of sensor (see spectral response graph).

The **Pyranometer** has a relatively large surface compared to many photo diode sensors. This minimises inaccuracies caused by the effect of rain drops and dirt on the surface. The sensor has a slightly domed top to facilitate rain drainage. Dirt sitting on the surface of the sensor is dispersed by rain flowing off the dome.

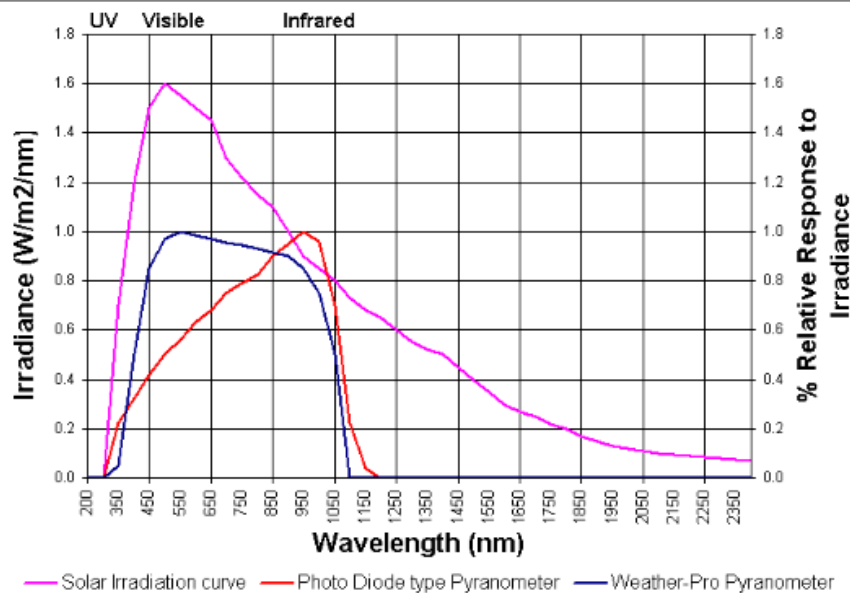

Spectral Response

The full terrestrial solar spectrum deposits measurable energy at the earth's surface in the range from 287 nanometres (nm) to beyond 4000 nm. However, as can be seen from the spectral response graph, the **pyranometer** measures the radiation between 300 and 1100 nanometres. As over 90% of the solar energy is between 300 to 1100 nm, the **pyranometer** is calibrated so as to estimate the short-wave component of the solar radiation.

Cosine Response Graph:

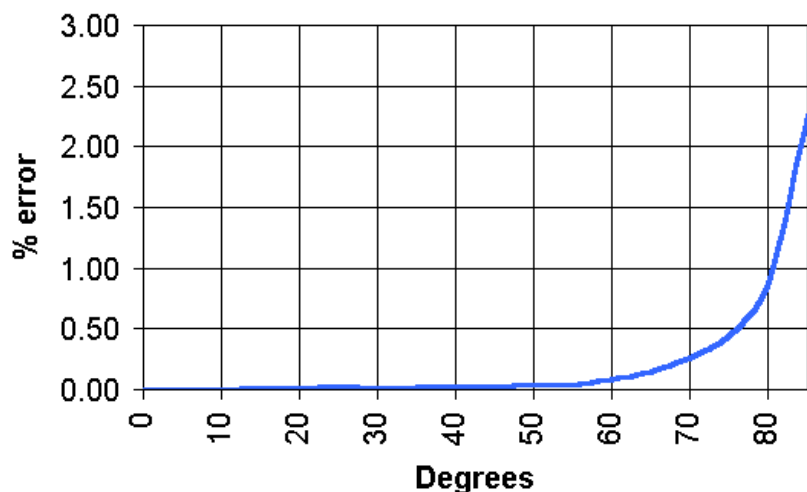

Cosine Response

An ideal pyranometer collects radiation from horizon to horizon and should therefore have a reception angle of 180° in all directions. In reality, some low angle radiation will not be detected because of the geometry of the sensor but this has been minimised by the sensor head design. As can be seen from the cosine response graph, the cosine error for this **Pyranometer** is typically less than 3% from vertical to 85° in all directions.

Other sources of error

The polycrystalline silicon solar cells have a temperature coefficient of 0.15% per 1°C. The **Pyranometer** is calibrated at 20°C giving a possible 3% error from 0°C to 40°C. The output of all radiation sensors tends to decrease over time as the detector ages. Our calculations estimate that the average decrease of the sensor is between 1% and 2 % per year.

Solar Radiation Shield — Model THP-CL

The **Solar Radiation Shield** is a chamber made from a series of fins that use the natural convection of warm air to draw fresh air into the chamber and expel the heated air. Temperature, Humidity and Pressure Sensors that are placed within the chamber will experience a flow of fresh air and so give more accurate measurements than sensors that are exposed to direct sunlight.

The fins are made from spun aluminium that has been powder coated white.

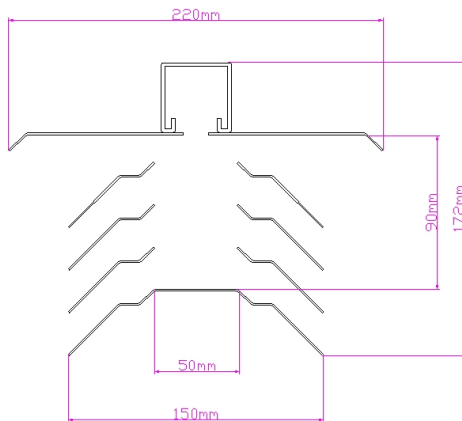

The **Solar Radiation Shield** is connected to the **T Bar Equipment Arm**. This is the most convenient way of mounting the shields to a tower, post or building.

The ventilated chamber within the **Solar Radiation Shield** is cylindrical in shape, 90mm high and 50mm in diameter.

This chamber is surrounded by a stainless steel mesh grill to protect the sensors from insects and wind blown debris.

If sunlight falls on sensors they absorb radiant energy directly from the sunlight and are therefore at a higher temperature than the surrounding air. This causes erroneous readings.

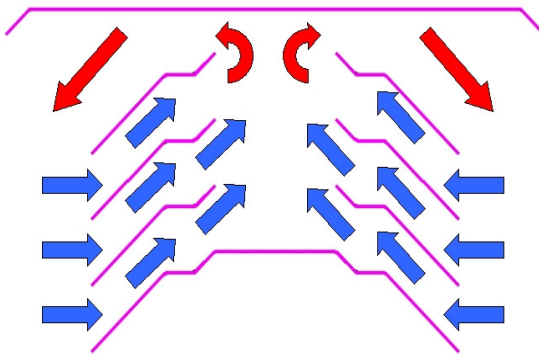

If the sensors are put into a chamber so that the direct sunlight can not strike them but the chamber and the air within it are heated this will also cause erroneous readings. If the chamber can be ventilated so that any heated air in chamber can rise and escape through convection then fresh air from the outside will be drawn in over the sensors and accurate readings of the air temperature, humidity and pressure can be made.

Humidity Sensor

The **HUMIREL HS1101** Humidity Sensor provides:

- Instantaneous de-saturation
- Solid polymer structure
- High resistance to chemicals
- Fast response time
- Range 0%~100%
- Accuracy RH $\pm 5\%$
- The Humidity Sensor is housed inside the Solar Radiation Shield

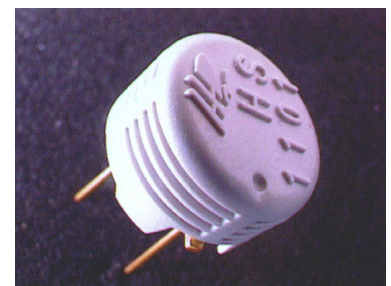

Temperature Sensor

The **Temperature Sensor** is a high accuracy thermister that has been factory calibrated to within 0.2 °C. This alleviates the need for any user calibration. The sensor has low thermal mass so as to ensure a fast response time.

- Temperature Range: -30°C~70°C
- Accuracy: $\pm 0.3^{\circ}\text{C}$ from (0°C~50°C)
- The Temperature Sensor is housed inside the Solar Radiation Shield

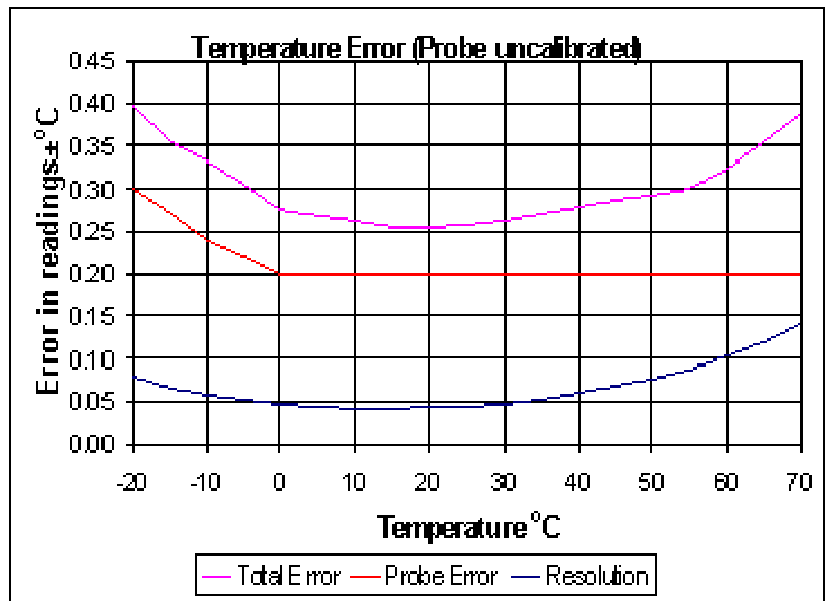

T Bar

The **T Bar** is specifically designed to give good separation between wind speed Anemometers and Wind Vanes. The total Length of the T bar is 800mm. The Bar is 41mm U section and is supplied with a plastic capping strip to cover the underside of the arm and two end caps. The Arm has an attachment plate in the centre with holes that can be used for mounting to 50mm (2inch) or 25mm (1inch) diameter pipe or bolting to posts or buildings.

The Arm is supplied complete with two 50mm (2inch) U bolts.



Base Mounting Plate

The **Base Mounting Plate** is used to facilitate the attachment of Wind Vanes, Anemometers and Solar Radiation Sensors to posts or buildings. Two countersunk holes in the centre of the plate are used to attach the base. The two outer holes are then used to attach the base to a post or building.

The outer holes are 5mm in diameter and 55mm apart. There is a groove in the plate to allow the cable, from the centre of the base, to emerge at the side of the **Base Mounting Plate**. When fitted in our factory, neutral cure translucent marine silicone rubber is used to seal the base to the **Base Mounting Plate**.

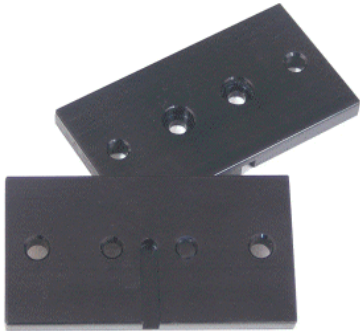

Base Mounting plates. Top plate showing the countersunk holes in the centre of the plate that are used to attach the base. Lower plate showing the cable groove.



Base attached to a Base Mounting Plate showing the cable exit

Typical Weather Sensor Transmitters Mounted on T Bar



Phone: **1-800-49-VESPO** or **1-239-348-8086**
Fax: **1-800-36-VESPO** or **1-239-348-9910**

VESPO
MARKETING ASSOCIATES, INC.