

# XI-L DC Transmitter.

Isolating 4~20mA Input  
to 4~20mA Output Loop  
Powered Transmitter.

## Features.

- Input to Output Isolation 1kV.
- High Accuracy 0.1%.
- Reverse Polarity Protected.
- Compact DIN Rail Mount Enclosure.
- Available With 1, 2 or 4 Transmitters per Enclosure.
- Easy to Install.
- Low Cost .



## Ordering Information.

XI-L1	One Unit Per Enclosure.
XI-L2	Two Units Per Enclosure.
XI-L4	Four Units Per Enclosure.

## XI-L Specifications.

Input	4~20mA.
Input Resistance	50Ω.
Output	2 wire 4~20mA. (Loop Powered.)
Output Load Resistance	800Ω @ 24Vdc. (50Ω/V Above 8Vdc.)
Power Supply	8~33Vdc.
Supply Voltage Sensitivity	<±0.005%/V FSO.
Maximum Output Current	Limited to <28mA.
EMC Emissions Compliance	EN 55022-A
EMC Immunity Compliance	EN 50082-1
Safety Compliance.	EN 60950
Accurate to	<±0.1% FSO Typical.
Linearity & Repeatability	<±0.1% FSO Typical.
Ambient Drift	<±0.01%/C FSO Typical.
Noise Immunity	125dB CMRR Average. (1.0kVdc Limit.)
R.F. Immunity	<1% Effect FSO Typical.
Isolation Test Voltages	-Between Input and Output: 1000Vdc for 1min. -Between the Separate XI-L transmitters: 1000Vdc for 1min.
Response Time	100msec Typical. (From 10 to 90% 25msec Typical.)
Operating Temperature	0~70C.
Storage Temperature	-20~80C.
Operating Humidity	5~85%RH Max. Non-Condensing.
Mounting	35mm Symmetrical Mounting Rail.
Dimensions	L=100, W=22.5, H=100mm.

## XI-L4 Enclosure Dimensions.

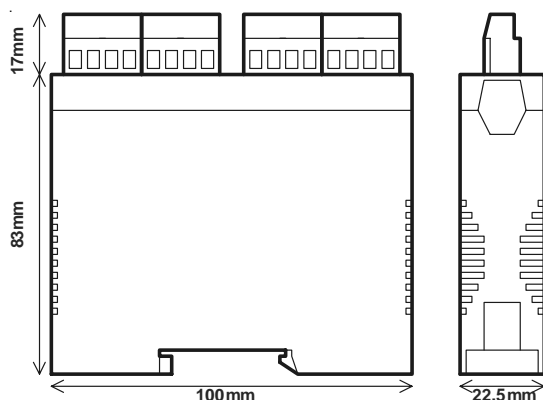

**Product Liability.** This information describes our products. It does not constitute guaranteed properties and is not intended to affirm the suitability of a product for a particular application. Due to ongoing research and development, designs, specifications, and documentation are subject to change without notification. Regrettably, omissions and exceptions cannot be completely ruled out. No liability will be accepted for errors, omissions or amendments to this specification. Technical data are always specified by their average values and are based on Standard Calibration Units at 25C, unless otherwise specified. Each product is subject to the 'Conditions of Sale'.

**Warning:** These products are not designed for use in, and should not be used for patient connected applications. In any critical installation an independant fail-safe back-up system must always be implemented.

## Quality Assurance Programme.

The modern technology and strict procedures of the ISO9001 Quality Assurance Programme applied during design, development, production and final inspection grant long term reliability of the instrument. This instrument has been designed and built to comply with EMC and Safety Standards requirements.

## XI-L: Top Overview of Terminals.

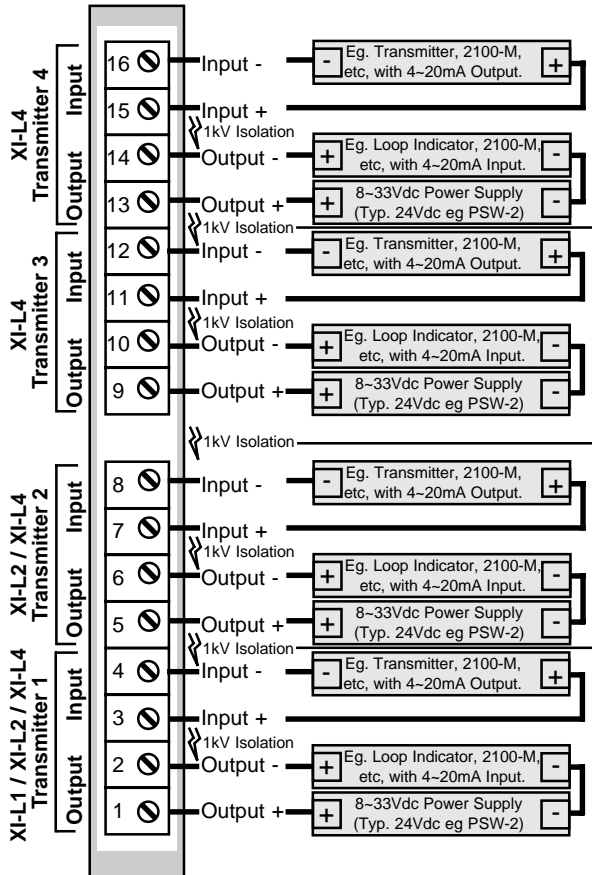

## Plan View of XI-L Adjustments.

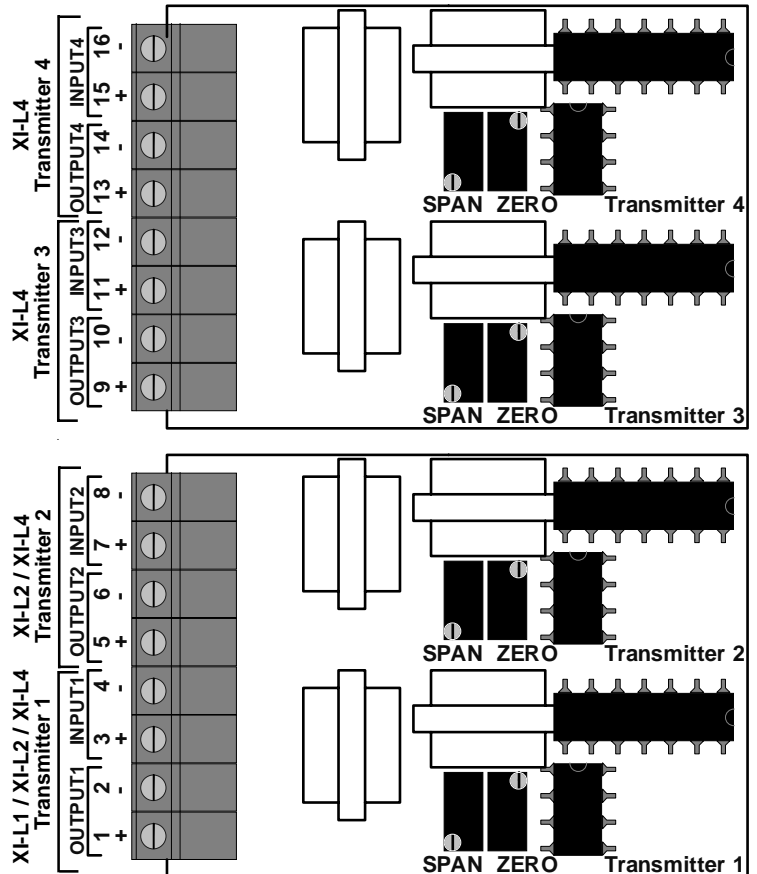

## The Proper Installation & Maintenance of XI-L.

All power and signals must be de-energised before connecting any wiring, or altering any Jumpers or Dip Switches.

### Mounting.

- (1) Mount in a clean environment in an electrical cabinet on DIN or EN mounting rail.
- (2) Draft holes must have minimum free air space of 20mm. Foreign matter must not enter or block draft holes.
- (3) Do not subject to vibration or excess temperature or humidity variations.
- (4) Avoid mounting in cabinets with power control equipment.
- (5) To maintain compliance with the EMC Directives the XI-L is to be mounted in a fully enclosed steel cabinet. The cabinet must be properly earthed, with appropriate input / output entry points and cabling.
- (6) Allow 10mm minimum clearance between the XI-L terminals and ANY conductive material.

### Cover Removal and Fitting.

To remove the PCB to access Pots, push in the GREY BUTTONS at both ends of the enclosure TOP, and slide the PCB from the BASE of the enclosure. To reassemble slide the PCB back into the BASE until both GREY BUTTONS 'snap' into place. Ensure the TOP of the enclosure is flush with the BASE on all sides.

### Wiring.

- (1) All cables should be good quality overall screened INSTRUMENTATION CABLE with the screen earthed at one end only.
- (2) Signal cables should be laid a minimum distance of 300mm from any power cables.
- (3) For 2 wire current loops and 2 wire voltage signals or 2 wire current signals, Austral Standard Cables B5102ES is recommended. For 3 wire transmitters Austral Standard Cables B5103ES is recommended.
- (4) It is recommended that you do not ground current loops and use power supplies with ungrounded outputs.
- (5) Lightning arrestors should be used when there is a danger from this source.
- (6) Refer to diagrams for connection information.

### Commissioning.

- (1) Once all the above conditions have been carried out and the wiring checked apply power to the XI-L loop and allow five minutes for it to stabilize.
- (2) Take a low (approx 10%) and high (approx 90%) reading of the variable being measured by the transducer supplying the signal to the XI-L, and ensure that this agrees with the level being indicated by the PLC or indicator, etc, that the XI-L is connected into. Adjust for any difference using the Zero & Spanpots mounted internally in the XI-L enclosure. (Refer to Plan View of XI-L Adjustments above.) Adjust the pots with a small screwdriver until the two levels agree. (Clockwise to increase the output reading and anti-clockwise to decrease the output.)

### MAINTENANCE.

- (1) Repeat (2) of Commissioning.
- (2) Do it regularly - at least once every 12 months.

**Intech** INSTRUMENTS LTD  
[www.intech.co.nz](http://www.intech.co.nz)  
 Christchurch Ph: +64 3 343 0646  
 Central Ph: 06 876 0034  
 Auckland Ph: 09 827 1930  
 Email: [sales@intech.co.nz](mailto:sales@intech.co.nz)