

XJ4 Transmitter

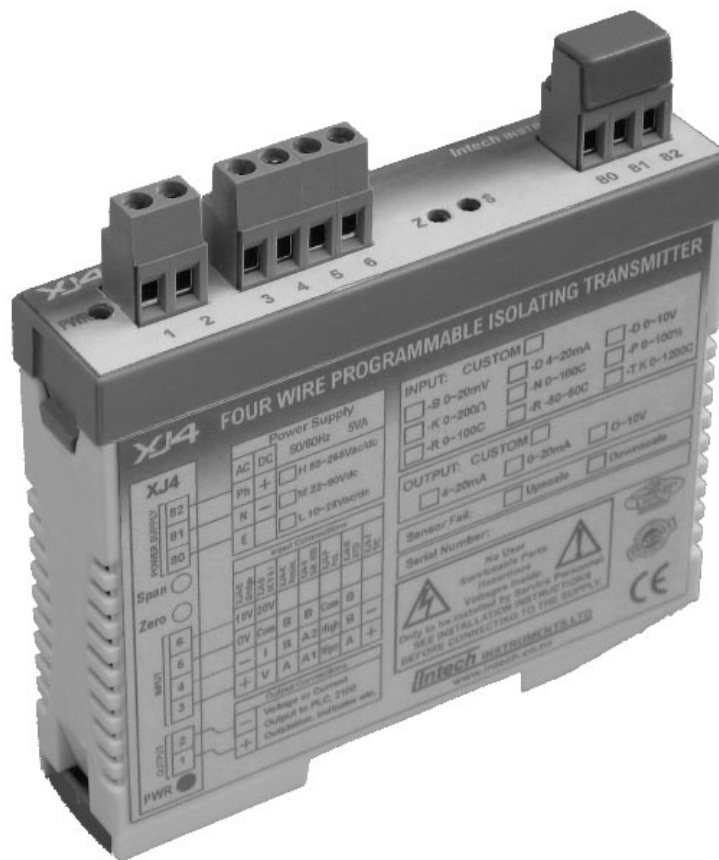

Z495



Installation Guide.

Section A. XJ4 Description, Ordering and Specifications.
XJ4 Installation Guide Index.

Section A. Description, Ordering and Specifications.

Index.	Page 2
Features and Ordering Information.	Page 3
Common Specifications.	Page 4
Terminals and layout.	Page 4
Dimensions.	Page 4
H1 Power Supply Jumper Settings.	Page 4
Individual Models Specifications.	Page 5
PCB Layout	Page 6

Section B. Calibration Information and Connection Examples.

Programming Notes.	Page 7
Zero Offset Calibration.	Page 7
XJ4-B Bridge/mV Input.	Page 7
XJ4-D DC Voltage Input.	Page 8
XJ4-D DC Current Input.	Page 8
XJ4-K Resistance Input.	Page 9
XJ4-N Differential RTD Input.	Page 9
XJ4-P Potentiometer Input.	Page 10
XJ4-R RTD Input.	Page 10
XJ4-T Thermocouple Input.	Page 11
Output Table.	Page 13
Programming Examples.	Page 13
XJ4 Model Solder Pads.	Page 14

Section C. Wiring, Installation, and Maintenance.

Mounting	Page 15
Cover Removal and Fitting.	Page 15
Power Supply Wiring.	Page 15
Analogue Signal Wiring.	Page 15
Potentiometers and Resistance.	Page 15
RTDs	Page 15
Thermocouples	Page 15
Thermocouple Extension Wire	Page 15
Commisioning.	Page 16
Maintenance.	Page 16

XJ4 Transmitter.

Programmable Isolating
Multi-Input to DC Current or
DC Voltage Output Transmitter.

Features.

- Field Programmable Bi-polar Input and Output Ranges.
- Input types:
 - mV, V, & mA.
 - RTD Pt100.
 - Differential RTD.
 - Thermocouple (T/C).
 - Bridge/Strain Guage.
 - Potentiometer.
 - Resistance.
- Input to Output Isolation 2.0kV.
- High Accuracy 0.1%.
- Universal AC/DC Power Supply.
- Transmitter Power Supply.
- Compact DIN Rail Mount Enclosure.
- Available Standard or Special Calibration.
- Low Cost.



Ordering Information.

XJ4-X Standard Calibration Unit: Input 4~20mA; Output 4~20mA; High Voltage Power Supply.

XJ4 - - - - - To order, select the Model, the Input Range, the Output Range, Sensor Break if appropriate, then the Power Supply Setting. Refer to the table below for selections. Other Special Input ranges available on request.

XJ4 - - - - -
M IR OR SB PS

Ranging Options of XJ4										
Input Model	M	Input Range - IR				Output Range - OR				
		Standard	or Specify Within		Min ¹⁾	Max ¹⁾	Voltage	OR	Current	OR
Bridge/Strainguage	B	0~20mV	0mV to 100mV & Bipolar		6mV	100mV	0~5V	A	0~10mA	1
DC Current	D	4~20mA	0mA to 26mA & Bipolar		60µA	26mA	0~10V	B	0~20mA	2
or DC Voltage	D	0~10V	0V to 40V & Bipolar		50mV	40V	1~5V	C	2~10mA	3
Resistance	K	0~200Ω	12Ω to 220Ω		12Ω	220Ω	2~10V	D	4~20mA	4
Differential RTD	N	0~100C	-100C to 520C	-150F to 940F	32C	520C	-5~5V	E	-10~10mA	5
Potentiometer	P	0~100%	0% to 100%		6%	100%	-10~10V	F	-20~20mA	6
RTD	R	0~100C	-100C to 520C	-150F to 940F	32C	520C				
Thermocouple	T	K: 0~1200C	B: 50C to 1820C	140F to 3310F	1100C	1820C				
			E: -270C to 1000C	-454F to 1840F	100C	1000C				
			J: -210C to 1200C	-350F to 2200F	110C	1200C				
			K: -270C to 1370C	-454F to 2500F	140C	1370C				
			L: -200C to 760C	-330F to 1400F	110C	760C				
			N: -270C to 1300C	-450F to 2380F	200C	1300C				
			R: -50C to 1760C	-60F to 3200F	650C	1760C				
			S: -50C to 1760C	-60F to 3200F	650C	1760C				
			T: -270C to 400C	-454F to 760F	140C	400C				
			U: -200C to 400C	-330F to 760F	140C	400C				
Note. All RTD and Thermocouple models are rangeable for both Celcius and Fahrenheit.										
Sensor Break	SB	POWER SUPPLY								PS
Upscale	U	High Voltage Power Supply: 85~264Vac/dc								H
Downscale	D	Mid Voltage Power Supply: 22~90Vdc								M
		Low Voltage Power Supply: 10~28Vac/dc								L

Note 1) Min or Max Input Span Range = Signal High - Signal Low. On any Span range, offsets from 0% to ±60% can be selected.

Note 2) The XJ4 can be field recalibrated from any Input Range, and Output range to any other Input Range, and Output Range.

To change the unit to a different Model (For example from XJ4-D to XJ4-T) ask your local distributor to reconfigure the unit.

Note 3) Power supply H is field selectable for M, and M for H. Power supply L must be ordered separately.

Note 4) Sensor Break option only applies to XJ4-K, XJ4-N, XJ4-R, XJ4-T only.

Ordering Examples.

1/ XJ4 - B - -10~30mV - B - L XJ4; Bridge, -10~30mV Input; 0~10V Output; 10~28Vac/dc PS.

2/ XJ4 - D - 0~200mV - 3 - H XJ4; DC, 0~200mV Input; 2~10mA Output; 85~264Vac/dc PS.

Quality Assurance Programme.

The modern technology and strict procedures of the ISO9001 Quality Assurance Programme applied during design, development, production and final inspection grant long term reliability of the instrument. This instrument has been designed and built to comply with EMC and Safety Standards requirements.

XJ4 Common Specifications.

Output	-Voltage	Field Programmable From 5V to ± 10 Vdc. Maximum Output Drive = 20mA. (500 Ω maximum load @ 10Vdc.)
	-Current	Field Programmable From 10mA to ± 20 mA. Maximum Output Drive = 15Vdc (750 Ω) @ +20mA. 10Vdc (500 Ω) @ -20mA.
Universal P/S:	-H	85~264Vac/dc; 50/60Hz; 5VA.
	-M	22~90Vdc; 5VA.
	-L	10~28Vac/dc; 50/60Hz; 5VA.
	-Circuit Sensitivity	$< \pm 0.001\%$ /V FSO Typical.
EMC Emissions Compliance		EN 55022-A
EMC Immunity Compliance		EN 50082-1
Safety Compliance.		EN 60950
Accurate to		$< \pm 0.1\%$ FSO Typical.
Linearity & Repeatability		$< \pm 0.1\%$ FSO Typical. (Unless Individual Specifications State Otherwise.)
Ambient Drift		$< \pm 0.01\%$ /C FSO Typical.
Noise Immunity		125dB CMRR Average. (2.0kVdc Limit.)
R.F. Immunity		$< 1\%$ Effect FSO Typical.
Mains Isolation		250Vac.
Mains Isolation Test Voltage		To Input/Output 3000Vac 50Hz for 1 min. To Earth 1500Vac 50Hz for 1 min.
Signal Isolation Test Voltage		Between Input and Output 2.0kVdc for 1 min.
Response Time		200msec Typical. (From 10 to 90% 50msec Typical.)
Operating Temperature		0~60C.
Storage Temperature		-20~80C.
Operating Humidity		5~85%RH Max. Non-Condensing.
Mounting		35mm Symmetrical Mounting Rail.
Dimensions		L=100, W=22.5, H=100mm.

Product Liability. This information describes our products. It does not constitute guaranteed properties and is not intended to affirm the suitability of a product for a particular application. Due to ongoing research and development, designs, specifications, and documentation are subject to change without notification. Regrettably, omissions and exceptions cannot be completely ruled out. No liability will be accepted for errors, omissions or amendments to this specification. Technical data are always specified by their average values and are based on Standard Calibration Units at 25C, unless otherwise specified. Each product is subject to the 'Conditions of Sale'.

Warning: These products are not designed for use in, and should not be used for patient connected applications. In any critical installation an independent fail-safe back-up system must always be implemented.

Top Overview of XJ4 Terminals.

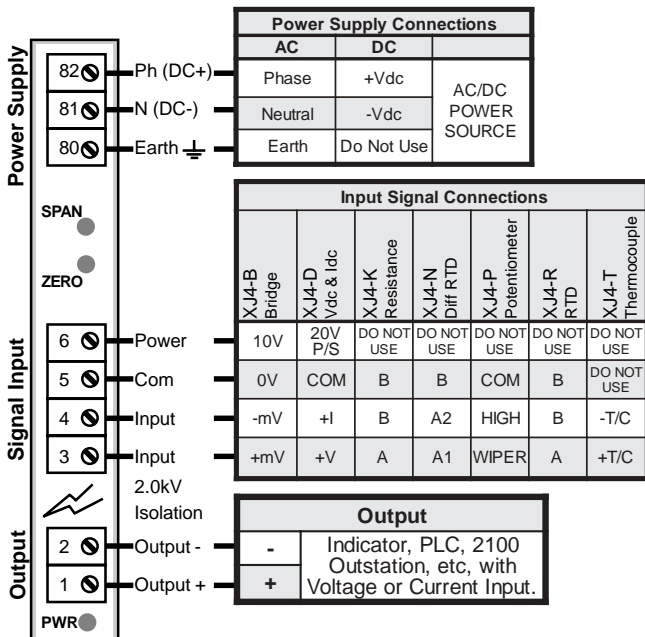

XJ4 Terminations.

Output	1 +Ve
	2 -Ve
Input	3 Signal
	4 Signal
	5 COM
	6 Signal Power
P/S	80 Earth \perp
	81 Neutral / -DC
	82 Phase / +DC

XJ4 H1 Power Supply Jumper Settings.

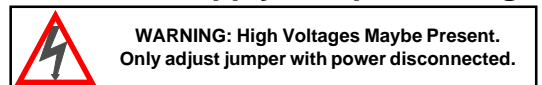

H1	Power Supply Voltage Range
H	Jumper for High: 85~264Vac/dc
M	Jumper for Mid: 22~90Vdc

Notes:

- 1/ H1 is approx 5cm behind the P/S terminals.
- 2/ Exceeding voltage ranges may damage the unit.
- 3/ Ensure the enclosure label is correctly labelled for the jumper position.
- 4/ Adjust H1 jumper with a pair of needle nose pliers.
- 5/ Low Voltage Power Supply version is fixed, and has no jumper. This must be ordered separately.

XJ4 Enclosure Dimensions.

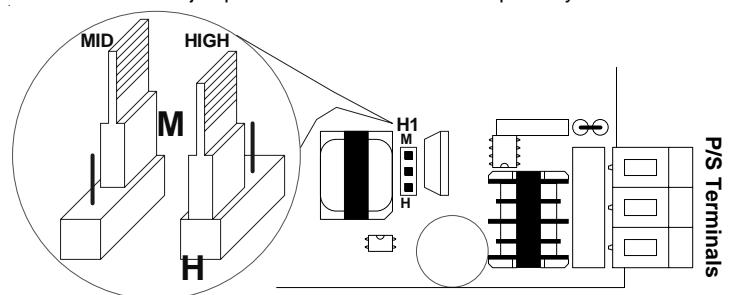
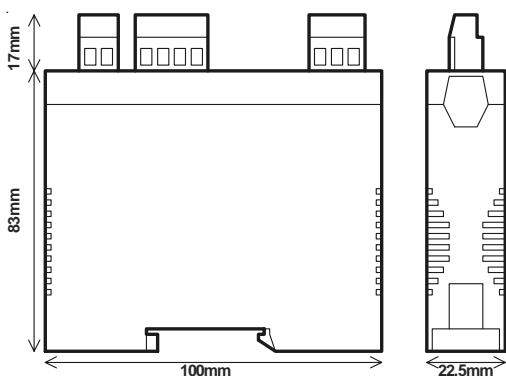

XJ4 Individual Models Specifications.

XJ4-B Bridge/Straingauge Input Specifications.

MilliVolts Input	-Field Programmable Zero	From 0 to $\pm 60\%$ of the Span.
	-Field Programmable Span	From 6mVdc to 100mVdc and Bipolar.
	-Minimum Input Resistance	130k Ω .
	-Maximum Over-range	40Vdc Continuous.
Bridge P/S	-Voltage	10Vdc $\pm 3\%$ Typical. (Voltage and Temperature Stable)
	-Max Load	30mA.. <10mV RMS Ripple Typical at 30mA Load.

XJ4-D DC Voltage or DC Current Input Specifications.

Voltage Input	-Field Programmable Zero	From 0 to $\pm 60\%$ of the Span.
	-Field Programmable Span	From 50mV to 40Vdc & Bipolar. (Special Higher Vdc available)
	-Minimum Input Resistance	130k Ω .
	-Maximum Over-range	40Vdc Continuous.
Current Input	-Field Programmable Zero	From 0 to $\pm 60\%$ of the Span.
	-Field Programmable Span	From 60 μ A to 26mAdc and Bipolar.
	-Input Resistance	100 Ω .
	-Maximum Over-range	50mAdc Continuous. (Special Higher mAdc available)
Transmitter P/S		20Vdc $\pm 10\%$ Common to Input Com.
	-Max Load	30mA. <10mV RMS Ripple Typical at 30mA Load.

XJ4-K Resistance Input Specifications.

Resistance Input		3 Wire Resistance. (2 Wire can be used with offset Calibration)
	-Lead Wire Resistance	5 Ω /Wire Max. 0.1%FSO Offset error per Ω of lead resistance.
	-Field Programmable Zero	From 0 to 60% of the Span.
	-Field Programmable Span	From 12 Ω to 220 Ω .
	-Linearity	0.1%FSO/20 Ω (0~20 Ω =0.1%FSO; 0~200 Ω =1%FSO)
	-Sensor Break Output Drive	Funct Jump 4='0' Upscale. Funct Jump 4='1' Downscale to within 5% of 0% FSO typical.
	Excitation Current	0.5mA Nominal

XJ4-N Differential RTD Input Specifications.

Differential RTD Input		Pt100 DIN (2 Wire Type) Standard.
	-Sensor Current	0.5mA Nominal.
	-Field Programmable Zero	From 0 to $\pm 60\%$ of the Span.
	-Field Programmable Span	From 32C(60F) to 520C(940F).
	-Sensor Break Output Drive	Funct Jump 4='0' RTD1 Break Upscale, RTD2 Break Downscale. Funct Jump 4='1' RTD1 Break Downscale, RTD2 Break Downscale.
	Linearity	0.1%FSO with RTD2=0.0C for SPAN Inputs \leq 200C. 0.2%FSO with RTD2=0.0C for SPAN Inputs \leq 520C.
Other Types of RTD Available:		JIS Pt100, Pt250, Pt500, Pt1000.

XJ4-P Potentiometer (Pot) Input Specifications.

Potentiometer Input		3 Wire Potentiometer.
	-Excitation Voltage	2.5Vdc.
	-Minimum Pot Resistance	1K Ω .
	-Maximum Pot Resistance	1M Ω .
	-Field Programmable Zero	From 0 to 60% of the Span.
	-Field Programmable Span	From 6 to 100%.

XJ4-R RTD Input Specifications.

RTD Input		Pt100 DIN 3 Wire Type. (2 Wire can be used with offset Calibration)
	-Sensor Current	0.5mA Nominal
	-Lead Wire Resistance	5 Ω /Wire Max. <0.1%FSO Offset error per Ω of lead resistance.
	-Field Programmable Zero	From 0 to $\pm 60\%$ of the Span.
	-Field Programmable Span	From 32C(60F) to 520C(940F).
	-Sensor Break Output Drive	Funct Jump 4='0' Upscale. Funct Jump 4='1' Downscale.
	Linearity	0.1%FSO for SPAN Inputs \leq 200C. 0.2%FSO for SPAN Inputs \leq 520C.
Other Types of RTD Available:		JIS Pt100, Pt250, Pt500, Pt1000.



CAUTION: Dangerous Voltages may be present. The XJ4 has no user serviceable parts. Protective enclosure only to be opened by qualified personnel. Remove ALL power sources before removing protective cover.



XJ4 Individual Models Specifications. Cont.

XJ4-T Thermocouple (T/C) Input Specifications.

Input	-Thermocouple	Types B, E, J, K, L, N, R, S, T, U.
	-Field Programmable Zero	From 0 to $\pm 60\%$ of the Span.
	-Field Programmable Span	Refer to Ordering Information for Min/Max Ranges for Each Type.
	-Input Impedance	130k Ω Minimum.
	-T/C Lead Resistance	100 Ω Maximum.
	-Cold Junction Comp.	0~50C.
	-CJC Accuracy -B, K, T, U	<0.05C/C (<0.05F/F) Typical.
	-CJC Accuracy -J, L, S	<0.1C/C (<0.1F/F) Typical.
	-CJC Accuracy -N, R	<0.2C/C (<0.2F/F) Typical.
	-CJC Accuracy -E	<0.3C/C (<0.3F/F) Typical.
	-Sensor Break Output Drive	Funct Jump 1='0' Downscale. Funct Jump 1='1' Upscale.

Note; Output is linear with mV input only. Output is not linear with temperature.

XJ4 PCB Layout

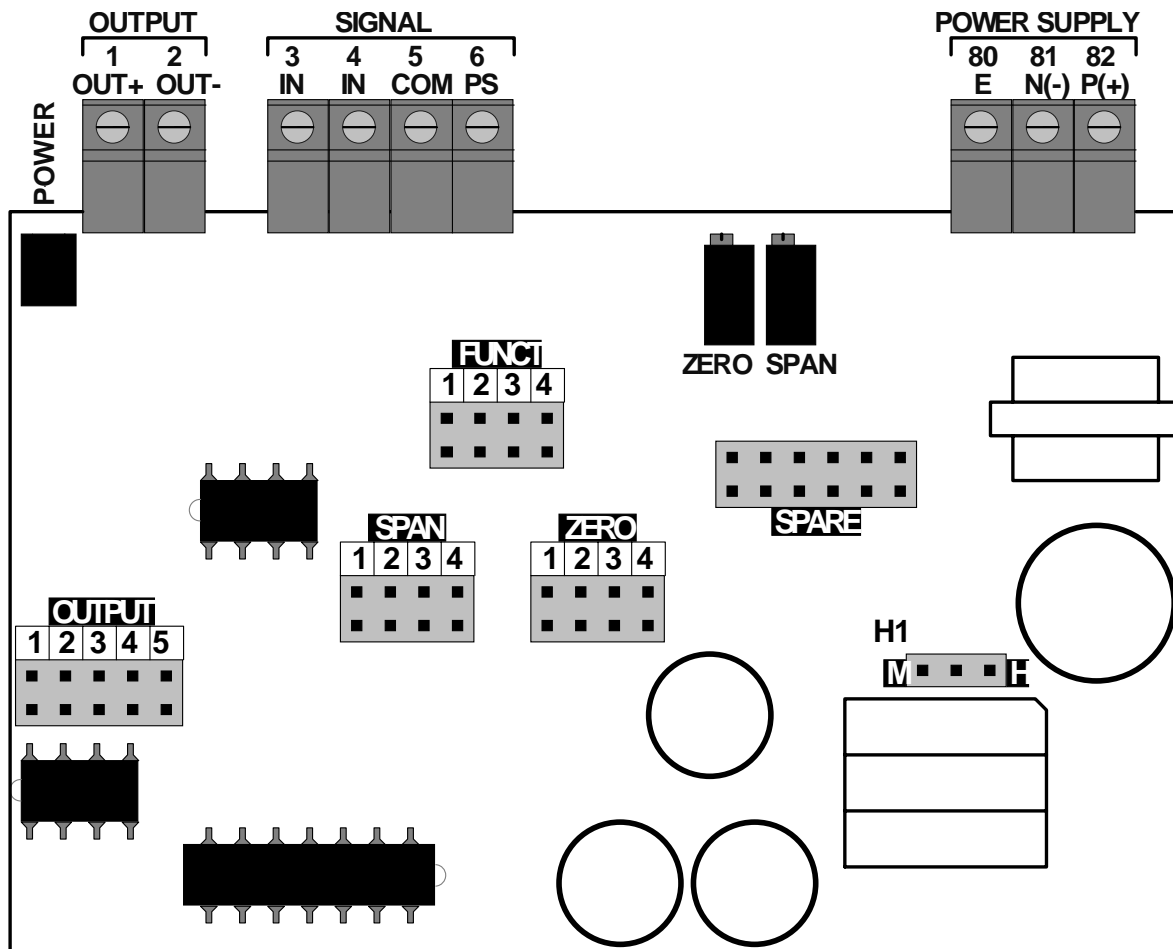

Note.

The header marked 'SPARE' has spare jumpers to be used for reranging. The 'SPARE' header has no electrical connection to the rest of the circuit.

	CAUTION: Dangerous Voltages may be present. The XJ4 has no user serviceable parts. Protective enclosure only to be opened by qualified personnel. Remove ALL power sources before removing protective cover.	
--	---------------------------------------------------------------------------------------------------------------------------------------------------------------------------------------------------------------------	--

Section B. XJ4 Calibration Information and Connection Examples.

Programming Notes.

These notes apply to all XJ4 MODELS AND RANGES.

- SPAN Input = Signal High – Signal Low. Refer SPAN Input Tables.
- ZERO Offset = Signal Low for Direct Acting Input. Refer ZERO Offset Table.
- ZERO Offset = Signal High for Reverse Acting Input. Reverse polarity of the input wires. Due to the large offset required for Reverse acting inputs only a few options are available. Refer ZERO Offset Table.
- ZERO Offset = Signal Low -32F for Degree F inputs. Refer ZERO Offset Table.
- ZERO and SPAN Pot adjustment Notes. (Do in this order)
 - If the ZERO Pot runs out of adjustment then adjust the SPAN Pot and then see if the ZERO Pot has come back within range.
 - If the ZERO Pot runs out of adjustment try the next ZERO jumper setting above or below. Refer to the ZERO Offset Table.
 - If the SPAN Pot runs out of adjustment try the next SPAN jumper setting above or below. Refer to the SPAN Input Table.
- All ZERO Offsets, SPAN Inputs and Pot adjustments are approximate only.
- Jumper status. '0' = Jumper not inserted. '1' = Jumper inserted.
- Ensure the XJ4 has been configured to the correct model. I.e. XJ4-B or XJ4-D or XJ4-K etc. To change to a different model ask your local distributor to reconfigure the unit. Refer to page 14.
- After re-ranging the unit check calibration and all functions. So check 0~100% In = 0~100% Out, Upscale or Downscale drive operates if applicable, CJC operates if applicable. If the Input or Output Ranges have been altered from factory settings the XJ4 must be recalibrated with certified calibration equipment.

Zero Offset Calibration.

ZERO Offset Table				
ZERO Offset	ZERO Jumpers			
	1	2	3	4
-40% of Maximum SPAN Input +/- 20% SPAN Input.	0	0	1	0
-20% of Maximum SPAN Input +/- 20% SPAN Input.	0	1	0	0
0% of Maximum SPAN Input +/- 20% SPAN Input.	1	0	0	1
20% of Maximum SPAN Input +/- 20% SPAN Input.	0	1	0	1
40% of Maximum SPAN Input +/- 20% SPAN Input.	0	0	1	1

Note.

- The 'Maximum SPAN Input' is the **Maximum** value on a line in a SPAN Input Table.
- The $\pm 20\%$ SPAN Input is achieved by adjusting the ZERO Pot.
- For Thermocouple SPAN Inputs only, for ZERO offset calculations the 'Maximum SPAN Input' is the number in () on the line you are using, in a SPAN Input table.

XJ4-B Bridge/mV Input.

Connection Example.

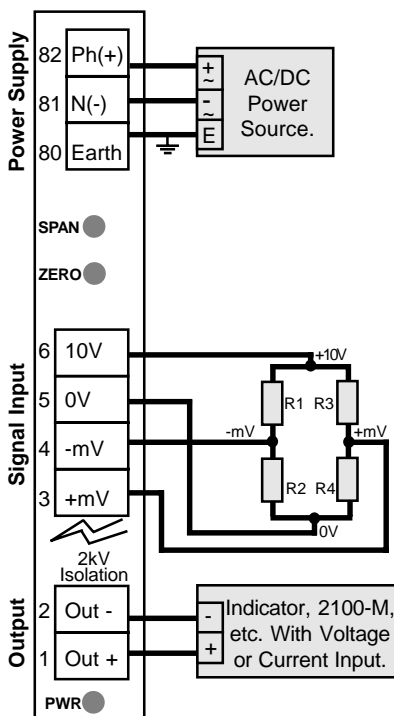

Span Input Programming Table.

XJ4-B mV SPAN Input Table								
SPAN INPUT	SPAN				FUNCT			
	1	2	3	4	1	2	3	4
6 to 12mV	1	0	0	0	0	0	0	0
12 to 25mV	0	1	0	0	0	0	0	0
25 to 50mV	0	0	1	0	0	0	0	0
50 to 100mV	0	0	0	1	0	0	0	0

Input Examples Programming Table.

XJ4-B mV Input Range Examples												
INPUT RANGE	ZERO				SPAN				FUNCT			
	1	2	3	4	1	2	3	4	1	2	3	4
0 ~ 20mV	1	0	0	1	0	1	0	0	0	0	0	0
20 ~ 100mV	0	1	0	1	0	0	0	1	0	0	0	0
-5 ~ 5mV	0	0	1	0	1	0	0	0	0	0	0	0

**XJ4-D DC Voltage Input.
Connection Example.**

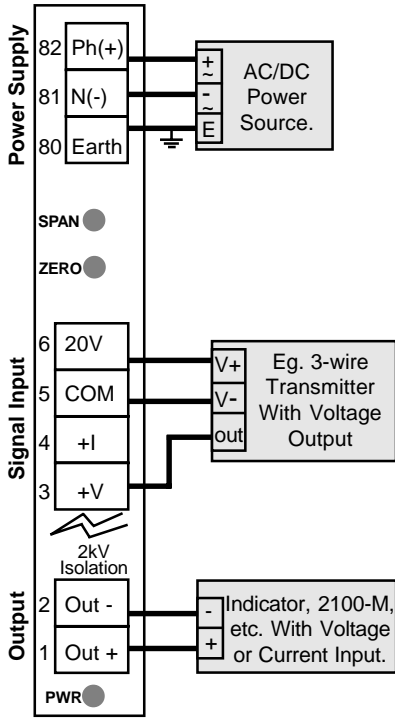

Span Input Programming Table.

XJ4-D V SPAN Input Table								
SPAN INPUT	SPAN				FUNCT			
	1	2	3	4	1	2	3	4
50 to 95mV	0	0	0	1	0	0	0	0
95 to 180mV	1	0	0	0	1	0	0	0
180 to 320mV	1	0	0	0	0	1	0	0
320 to 650mV	0	1	0	0	0	1	0	0
0.65 to 1.3V	0	0	1	0	0	1	0	0
1.3 to 2.4V	0	0	0	1	0	1	0	0
2.4 to 4.8V	1	0	0	0	1	1	0	0
4.8 to 9.6V	0	1	0	0	1	1	0	0
9.6 to 19.2V	0	0	1	0	1	1	0	0
19.2 to 40V	0	0	0	1	1	1	0	0

Input Examples Programming Table.

XJ4-D V Input Range Examples												
INPUT RANGE	ZERO				SPAN				FUNCT			
	1	2	3	4	1	2	3	4	1	2	3	4
0 ~ 10V	1	0	0	1	0	0	1	0	1	1	0	0
1 ~ 5V	0	1	0	1	1	0	0	0	1	1	0	0
-10 ~ 10V	0	1	0	0	0	0	0	1	1	1	0	0
*10 ~ 0V	0	0	1	0	0	0	1	0	1	1	0	0

* For reverse acting inputs reverse the polarity of the input wires.

**XJ4-D DC Current Input.
Connection Example.**

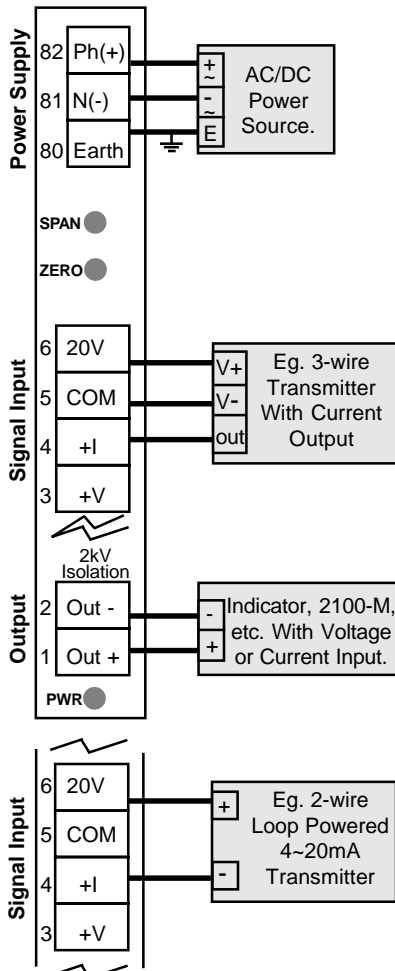

Span Input Programming Table.

XJ4-D I SPAN Input Table								
SPAN INPUT	SPAN				FUNCT			
	1	2	3	4	1	2	3	4
60 to 120uA	1	0	0	0	1	0	0	0
120 to 250uA	0	1	0	0	1	0	0	0
250 to 500uA	0	0	1	0	1	0	0	0
0.5 to 1mA	0	0	0	1	1	0	0	0
1.5 to 3.2mA	1	0	0	0	1	1	0	0
3.2 to 6.5mA	0	1	0	0	1	1	0	0
6.5 to 13mA	0	0	1	0	1	1	0	0
13 to 26mA	0	0	0	1	1	1	0	0

Input Examples Programming Table.

XJ4-D I Input Range Examples												
INPUT RANGE	ZERO				SPAN				FUNCT			
	1	2	3	4	1	2	3	4	1	2	3	4
4 ~ 20mA	0	1	0	1	0	0	0	1	1	1	0	0
0 ~ 10mA	1	0	0	1	0	0	1	0	1	1	0	0
-1 ~ 1mA	0	0	1	0	1	0	0	0	1	1	0	0

**XJ4-K Resistance Input.
Connection Example.**

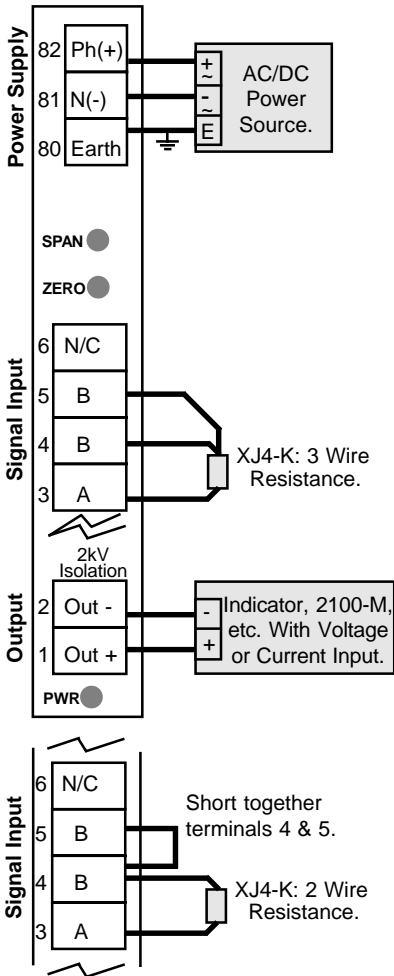

Span Input Programming Table.

XJ4-K Resistance SPAN Input Table								
SPAN INPUT	SPAN				FUNCT			
	1	2	3	4	1	2	3	4
12 to 26 Ohm	1	0	0	0	0	0	0	0
26 to 55 Ohm	0	1	0	0	0	0	0	0
55 to 110 Ohm	0	0	1	0	0	0	0	0
110 to 220 Ohm	0	0	0	1	0	0	0	0

Notes.

- Linearity 0.1% FSO per 20 Ohm of Resistance.
eg. 20 Ohm = 0.1% FSO. 200 Ohm = 1% FSO.
- Funct Jump 4 = '0'. On Sensor Break output will drive upscale.
Funct Jump 4 = '1'. On Sensor Break output will drive to within 5% of 0% FSO typical.

Input Examples Programming Table.

XJ4-K Resistance Input Range Examples												
INPUT RANGE	ZERO				SPAN				FUNCT			
	1	2	3	4	1	2	3	4	1	2	3	4
0 ~ 200 Ohm	1	0	0	1	0	0	0	1	0	0	0	0
50 ~ 150 Ohm	0	0	1	1	0	0	1	0	0	0	0	0

Note. All examples on Sensor Break output will drive upscale.

**XJ4-N Differential RTD Input.
Connection Example.**

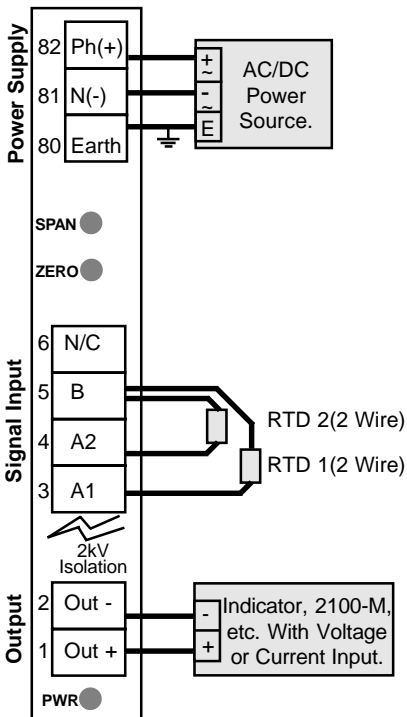

Span Input Programming Table.

XJ4-N Differential RTD SPAN Input Table									
SPAN INPUT		SPAN				FUNCT			
Deg C	Deg F	1	2	3	4	1	2	3	4
32 to 65C	60 to 115F	1	0	0	0	0	0	0	*
65 to 130C	115 to 230F	0	1	0	0	0	0	0	*
130 to 260C	230 to 470F	0	0	1	0	0	0	0	*
260 to 520C	470 to 940F	0	0	0	1	0	0	0	*

Notes.

- *Function Jumper 4 = '0'. On RTD1 Sensor Break output will drive upscale & on RTD2 Sensor Break output will drive Downscale.
*Function Jumper 4 = '1'. On RTD1 or RTD2 Sensor Break output will drive downscale.
- Linearity is specified with RTD2 = 0.0C
- RTD1 and RTD2 are 2 wire RTD's.
- All Deg F allow for 32 Deg Offset. Refer Programming Notes.

Input Examples Programming Table.

XJ4-N Differential RTD Input Range Examples												
INPUT RANGE	ZERO				SPAN				FUNCT			
	1	2	3	4	1	2	3	4	1	2	3	4
0 ~ 100C	1	0	0	1	0	1	0	0	0	0	0	0
0 ~ 200C	1	0	0	1	0	0	1	0	0	0	0	0
-20 ~ 30C	0	0	1	0	1	0	0	0	0	0	0	0
-50 ~ 50C	0	0	1	0	0	1	0	0	0	0	0	0
0 ~ 100F	0	1	0	0	1	0	0	0	0	0	0	0
0 ~ 200F	0	1	0	0	0	1	0	0	0	0	0	0
-30 ~ 70F	0	0	1	0	1	0	0	0	0	0	0	0
-100 ~ 100F	0	0	1	0	0	1	0	0	0	0	0	0

Note. All examples on RTD1 Sensor Break output will drive upscale & on RTD2 Sensor Break output will drive Downscale.

**XJ4-P Potentiometer Input.
Connection Example.**

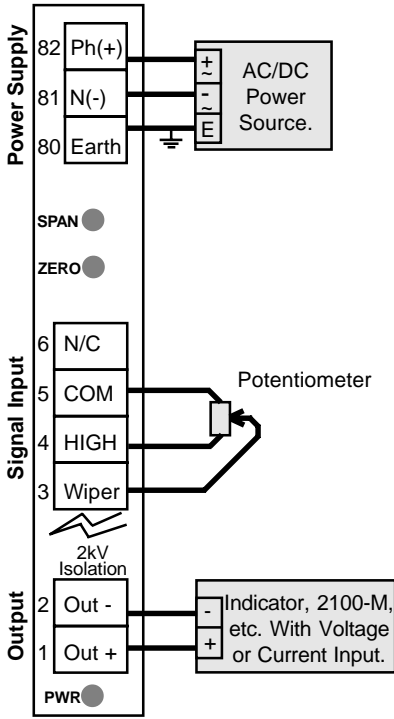

Span Input Programming Table.

XJ4-P Potentiometer SPAN Input Table								
SPAN INPUT	SPAN				FUNCT			
	1	2	3	4	1	2	3	4
6 to 13%	1	0	0	0	0	1	0	0
13 to 26%	0	1	0	0	0	1	0	0
26 to 52%	0	0	1	0	0	1	0	0
52 to 100%	0	0	0	1	0	1	0	0

Note. Minimum Pot Resistance 1KΩ.
Maximum Pot Resistance 1MΩ.

Input Examples Programming Table.

XJ4-P Pot Input Range Examples												
INPUT RANGE	ZERO				SPAN				FUNCT			
	1	2	3	4	1	2	3	4	1	2	3	4
0 ~ 100%	1	0	0	1	0	0	0	1	0	1	0	0
25 ~75%	0	0	1	1	0	0	1	0	0	1	0	0

**XJ4-R RTD Input.
Connection Example.**

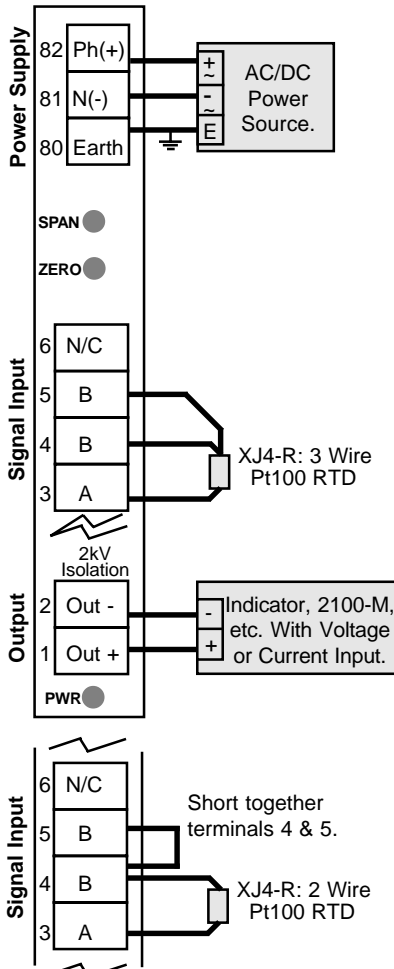

Span Input Programming Table.

XJ4-R RTD SPAN Input Table										
SPAN INPUT		SPAN				FUNCT				
Deg C	Deg F	1	2	3	4	1	2	3	4	
32 to 65C	60 to 115F	1	0	0	0	0	0	0	*	
65 to 130C	115 to 230F	0	1	0	0	0	0	0	*	
130 to 260C	230 to 470F	0	0	1	0	0	0	0	*	
260 to 520C	470 to 940F	0	0	0	1	0	0	0	*	

Notes.

- *Function Jumper 4 = '0'. On RTD Sensor Break output will drive upscale.
*Function Jumper 4 = '1'. On RTD Sensor Break output will drive downscale.
- The RTD can be 2 or 3 wire and max resistance per leg is 5Ω.
- All Deg F allow for 32 Deg Offset. Refer Programming Notes.

Input Examples Programming Table.

XJ4-R RTD Input Range Examples												
INPUT RANGE	ZERO				SPAN				FUNCT			
	1	2	3	4	1	2	3	4	1	2	3	4
0 ~ 100C	1	0	0	1	0	1	0	0	0	0	0	0
0 ~ 200C	1	0	0	1	0	0	1	0	0	0	0	0
-20 ~ 30C	0	0	1	0	1	0	0	0	0	0	0	0
-50 ~ 50C	0	0	1	0	0	1	0	0	0	0	0	0
0 ~ 100F	0	1	0	0	1	0	0	0	0	0	0	0
0 ~ 200F	0	1	0	0	0	1	0	0	0	0	0	0
-30 ~ 70F	0	0	1	0	1	0	0	0	0	0	0	0
-100 ~ 100F	0	0	1	0	0	1	0	0	0	0	0	0

Note. All examples on RTD Sensor Break output will drive upscale.

XJ4-T Thermocouple Input.
Connection Example.

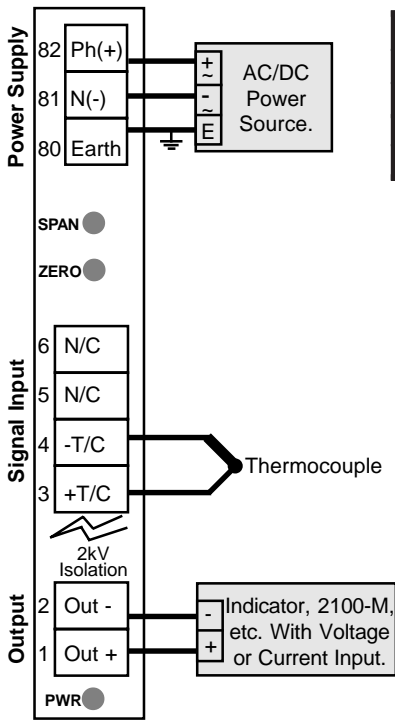

Type B Thermocouple Span Input Programming Table.

XJ4-T B Thermocouple SPAN Input Table											
SPAN INPUT		SPAN				FUNCT					
Deg C	Deg F	1	2	3	4	1	2	3	4		
1100 to 1650C	2000 to 3000F	1	0	0	0	*	0	0	0		
1650 to 1820C (3330)	3000 to 3310F (6050)	0	1	0	0	*	0	0	0		

Type B Thermocouple Input Examples Programming Table.

XJ4-T B T/C Input Range Examples												
INPUT RANGE	ZERO				SPAN				FUNCT			
	1	2	3	4	1	2	3	4	1	2	3	4
B 0 ~ 1800C	1	0	0	1	0	1	0	0	1	0	0	0
B 0 ~ 3200F	1	0	0	1	0	1	0	0	1	0	0	0

Notes for all Thermocouple Types.

- *Function Jumper 1 = '0'. On T/C Sensor Break output will drive downscale.
 *Function Jumper 1 = '1'. On T/C Sensor Break output will drive upscale.
- For individual minimum & maximum Thermocouple ranges refer to specifications.
- All examples on Thermocouple Sensor Break output will drive upscale.
- For Deg F allow for 32 Deg Offset. Refer Programming Notes.
- Thermocouples are linear with mV. They are not linear with temperature.

Type E Thermocouple Span Input Programming Table.

XJ4-T E Thermocouple SPAN Input Table									
SPAN INPUT		SPAN				FUNCT			
Deg C	Deg F	1	2	3	4	1	2	3	4
E 100 to 175C	E 180 to 320F	1	0	0	0	*	1	1	0
E 175 to 340C	E 320 to 610F	0	1	0	0	*	1	1	0
E 340 to 630C	E 610 to 1130F	0	0	1	0	*	1	1	0
E 630 to 1000C (1260)	E 1130 to 1840F (2280)	0	0	0	1	*	1	1	0

Type E Thermocouple Input Examples Programming Table.

XJ4-T E T/C Input Range Examples												
INPUT RANGE	ZERO				SPAN				FUNCT			
	1	2	3	4	1	2	3	4	1	2	3	4
E 0 ~ 700C	1	0	0	1	0	0	0	1	1	1	1	0
E 0 ~ 1300F	1	0	0	1	0	0	0	1	1	1	1	0

Type J or L Thermocouple Span Input Programming Table.

XJ4-T J or L Thermocouple SPAN Input Table									
SPAN INPUT		SPAN				FUNCT			
Deg C	Deg F	1	2	3	4	1	2	3	4
J or L 110 to 215C	J or L 200 to 390F	1	0	0	0	*	1	1	0
J or L 215 to 430C	J or L 390 to 770F	0	1	0	0	*	1	1	0
J or L 430 to 830C	J or L 770 to 1490F	0	0	1	0	*	1	1	0
J 830 to 1200C (1660)	J 1490 to 2200F (3000)	0	0	0	1	*	1	1	0

Type J or L Thermocouple Input Examples Programming Table.

XJ4-T J or L T/C Input Range Examples												
INPUT RANGE	ZERO				SPAN				FUNCT			
	1	2	3	4	1	2	3	4	1	2	3	4
J or L 0 ~ 400C	1	0	0	1	0	1	0	0	1	1	1	0
J or L 0 ~ 600C	1	0	0	1	0	0	1	0	1	1	1	0
J or L 0 ~ 1000F	1	0	0	1	0	0	1	0	1	1	1	0

XJ4-T Thermocouple Input Cont.

Type K Thermocouple Span Input Programming Table.

XJ4-T K T/C SPAN Input Table									
SPAN INPUT		SPAN				FUNCT			
Deg C	Deg F	1	2	3	4	1	2	3	4
K 140 to 285C	K 250 to 510F	1	0	0	0	*	1	0	0
K 285 to 580C	K 510 to 1040F	0	1	0	0	*	1	0	0
K 580 to 1160C	K 1040 to 2090F	0	0	1	0	*	1	0	0
K 1160 to 1370C (2400)	K 2900 to 2500F (4330)	0	0	0	1	*	1	0	0

Type K Thermocouple Input Examples Programming Table.

XJ4-T K T/C Input Range Examples												
INPUT RANGE	ZERO				SPAN				FUNCT			
	1	2	3	4	1	2	3	4	1	2	3	4
K -100 ~ 400C	0	1	0	0	0	1	0	0	1	1	0	0
K 0 ~ 1200C	1	0	0	1	0	0	0	1	1	1	0	0
K 0 ~ 2200F	1	0	0	1	0	0	0	1	1	1	0	0

Type N Thermocouple Span Input Programming Table.

XJ4-T N T/C SPAN InputTable									
SPAN INPUT		SPAN				FUNCT			
Deg C	Deg F	1	2	3	4	1	2	3	4
N 200 to 365C	N 360 to 660F	1	0	0	0	*	1	0	0
N 365 to 690C	N 660 to 1240 F	0	1	0	0	*	1	0	0
N 690 to 1300C (1370)	N 1240 to 2380F (2470)	0	0	1	0	*	1	0	0

Type N Thermocouple Input Examples Programming Table.

XJ4-T N T/C Input Range Examples												
INPUT RANGE	ZERO				SPAN				FUNCT			
	1	2	3	4	1	2	3	4	1	2	3	4
N 0 ~ 1300C	1	0	0	1	0	0	1	0	1	1	0	0
N 0~ 2300F	1	0	0	1	0	0	1	0	1	1	0	0

Type T or U Thermocouple Span Input Programming Table.

XJ4-T T or U T/C SPAN Input Table									
SPAN INPUT		SPAN				FUNCT			
Deg C	Deg F	1	2	3	4	1	2	3	4
T or U 130 to 245C	T or U 240 to 440F	1	0	0	0	*	1	1	0
T or U 245 to 400C (470)	T or U 440 to 760F (860)	0	1	0	0	*	1	1	0

Type T or U Thermocouple Input Examples Programming Table.

XJ4-T T or U T/C Input Range Examples												
INPUT RANGE	ZERO				SPAN				FUNCT			
	1	2	3	4	1	2	3	4	1	2	3	4
T or U -200~200C	0	1	0	0	0	1	0	0	1	1	1	0
T or U 0 ~ 400C	1	0	0	1	0	1	0	0	1	1	1	0
T or U -300 ~ 400F	0	1	0	0	0	1	0	0	1	1	1	0

Type R or S Thermocouple Span Input Programming Table.

XJ4-T R or S T/C SPAN Input Table									
SPAN INPUT		SPAN				FUNCT			
Deg C	Deg F	1	2	3	4	1	2	3	4
R or S 650 to 1150C	R or S 1200 to 2060F	1	0	0	0	*	0	1	0
R or S 1150 to 1760C (2100)	R or S 2060 to 3200F (3800)	0	1	0	0	*	0	1	0

Type R or S Thermocouple Input Examples Programming Table.

XJ4-T R or S T/C Input Range Examples												
INPUT RANGE	ZERO				SPAN				FUNCT			
	1	2	3	4	1	2	3	4	1	2	3	4
R or S 0 ~ 1700C	1	0	0	1	0	1	0	1	1	0	1	0
R or S 0 ~ 3100F	1	0	0	1	0	1	0	0	1	0	1	0

XJ4 Output Table.

XJ4 Output Range Table.											
Output Range (V)	OUTPUT JUMPERS					Output Range (I)	S2-Function				
	1	2	3	4	5		1	2	3	4	5
0 ~ 5V	0	1	0	1	1	0 ~ 10mA	0	1	0	0	0
0 ~ 10V	0	1	1	1	1	0 ~ 20mA	0	1	1	0	0
1 ~ 5V	1	1	0	1	1	2 ~ 10mA	1	1	0	0	0
2 ~ 10V	1	1	1	1	1	4 ~ 20mA	1	1	1	0	0
-5 ~ 5V	0	0	0	1	1	-10 ~ 10mA	0	0	0	0	0
-10 ~ 10V	0	0	1	1	1	-20 ~ 20mA	0	0	1	0	0

Note; For mV output place a resistor across the mA output.

Eg: If 0 ~ 20mV output is required, place a 1Ω resistor across 0 ~ 20mA Output Terminals = 0 ~ 20mV Output.

XJ4 Programming Examples.

Example 1. 4~20mA Input = -10~10V Output.

- SPAN Range = 20 – 4 = 16mA.
From 'XJ4-D SPAN Range Table' 16mA is within the range '13 to 26mA'.
=> **SPAN Jumpers = 0001.**
=> **FUNCT Jumpers = 1100.**
- ZERO Offset = Signal Low = 4mA.
From the ZERO Offset Table 4mA is within the ZERO offset '20% of Maximum Range ±20% Input SPAN Range'. (20% of 26mA ±20% of 16mA = 5.2 ±3.2mA = 2 to 8.4mA)
=> **ZERO Jumpers = 0101.**
- Output Range -10~10 V. From 'Output Range Table'
=> **OUTPUT Jumpers = 00111.**
- ZERO Pot Adjust for 4mA Input = -10V Output.
- SPAN Pot Adjust for 20mA Input = +10V Output.
- Repeat ZERO and SPAN pot adjustment until 4~20mA Input = -10~10V Output.

Example 2. RTD -50~50C Input = 4~20mA Output. Upscale Drive required on Sensor Break.

- SPAN Range = 50 – -50 = 100C.
- From 'XJ4-R SPAN Range Table' 100C is within the range 65 to 130C.
=> **SPAN Jumpers = 0100.**
=> **FUNCT Jumpers = 0000. (Function Jumper 4 = 0 for Upscale Drive.)**
- ZERO Offset = Signal Low = -50C.
From the ZERO Offset Table -50C is within the ZERO offset '-40% of Maximum Range ±20% Input SPAN Range'. (-40% of 130C ±20% of 100C = -52 ±20C = -32 to -72C)
=> **ZERO Jumpers = 0010.**
- Output Range 4~20mA. From 'Output Range Table'
=> **OUTPUT Jumpers = 11100.**
- ZERO Pot Adjust for -50C Input = 4mA Output.
- SPAN Pot Adjust for +50C Input = 20mA Output.
- Repeat ZERO and SPAN pot adjustment until -50~50C Input = 4~20mA Output.
- Disconnect the 'A' RTD leg and check the Output Drives Upscale.

Example 3. T/C K -200~600F Input = 0~10V Output. Upscale Drive required on Sensor Break.

- SPAN Range = 600 - -200 = 800F.
- From 'XJ4-T SPAN Range Table' 800F is within the range 530 to 1050F.
=> **SPAN Jumpers = 0100.**
=> **FUNCT Jumpers = 1110. (Function Jumper 1 = 1 for Upscale Drive.)**
- ZERO Offset = Signal Low -32F = -200F – 32F = -232F.
From the ZERO Offset Table -232F is within the ZERO offset '-20% of Maximum Range ±20% Input SPAN Range'. (-20% of 1050F ±20% of 800F = -210 ±160F = -370 to -50F)
=> **ZERO Jumpers = 0100.**
- Output Range 0~10V. From 'Output Range Table'
=> **OUTPUT Jumpers = 01111.**
- ZERO Pot Adjust for -200F Input = 0V Output.
- SPAN Pot Adjust for +600F Input = 10V Output.
- Repeat ZERO and SPAN pot adjustment until -200~600F Input = 0~10V Output.
- Disconnect the '+' T/C leg and check the Output Drives Upscale.
- Short the + and – input with a 0R link and check the output tracks ambient temperature.

XJ4 Model Solder Pads. Distributor Ranging Information Only.

To range the XJ4 to a different Input Model re-solder the solder pad to match the configuration below. Follow anti-static procedures at all times. Use only an electronic temperature controlled soldering iron with a maximum tip width of 1.6mm. Tip temperature must be set to less than 380C.

Removing Solder: Do not use a solder sucker to remove solder from the solder pads - they can lift pads and damage the PCB. Instead wipe the soldering iron tip with clean **dry** cotton material. The existing solder will adhere to the clean tip, removing it from the pads. This is a better and quicker method than using a solder sucker.

Resoldering Pads: To solder pads use suitable electronic grade multicore solder. Check all solder joints are well made and in the correct positions. Failure to follow this procedure can result in unreliable performance due to damage to the PCB and solder pads lifting.

CAUTION: Dangerous Voltages may be present. The XJ4 has no user serviceable parts. Protective enclosure only to be opened by qualified personnel. Remove ALL power sources before removing protective cover.

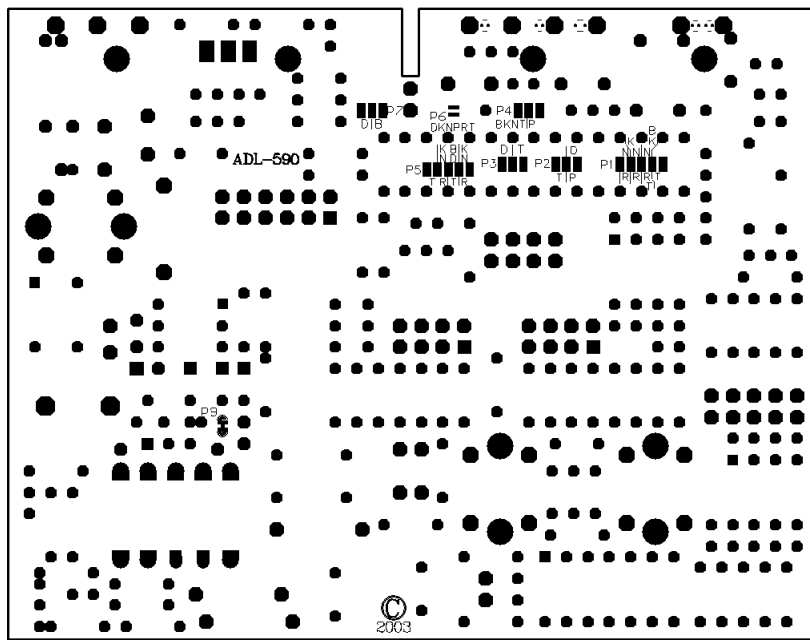
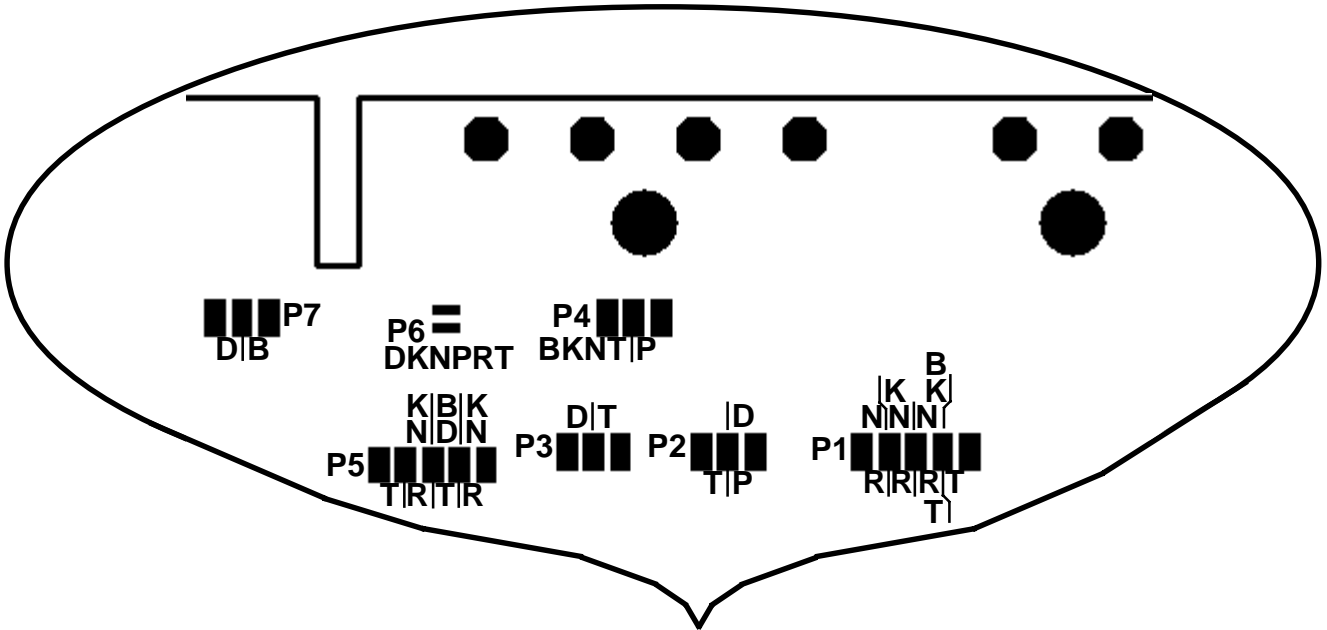

Solder Pad Configurations.
 '▣' = SOLDER PAD.

XJ4-B

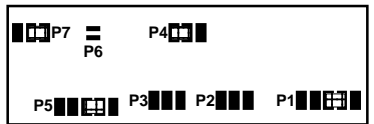

XJ4-D



XJ4-K

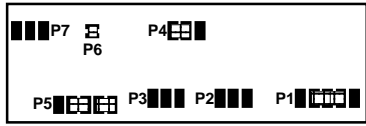

XJ4-N

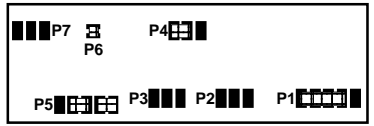

XJ4-P

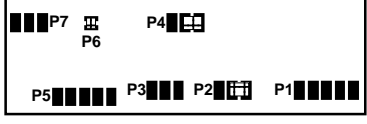

XJ4-R

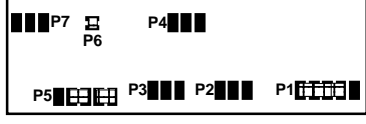

XJ4-T

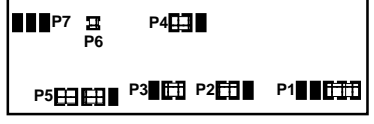

Section C. XJ4 Wiring, Installation and Maintenance.

THE XJ4 IS TO BE INSTALLED AND SERVICED BY SERVICE PERSONNEL ONLY. NO OPERATOR / USER SERVICEABLE PARTS.

All power and signals must be de-energised before connecting any wiring, or altering any Jumpers.

Mounting.

* Also refer to Connection Diagrams and Notes.

- (1) Mount in a clean environment in an electrical cabinet on 35mm Symmetrical mounting rail.
- (2) Draft holes must have minimum free air space of 20mm. Foreign matter must not enter or block draft holes.
- (3) Do not subject to vibration or excess temperature or humidity variations.
- (4) Avoid mounting in cabinets with power control equipment.
- (5) To maintain compliance with the EMC Directives the XJ4 is to be mounted in a fully enclosed steel fire cabinet. The cabinet must be properly earthed, with appropriate input / output entry points and cabling.
- (6) Allow 10mm minimum clearance between the XJ4 terminals and ANY conductive material.

Cover Removal and Fitting.

To remove the PCB to access jumpers, push in the GREY BUTTONS at both ends of the enclosure TOP, and slide the PCB from the BASE of the enclosure. To reassemble slide the PCB back into the BASE until both GREY BUTTONS 'snap' into place. Ensure the TOP of the enclosure is flush with the BASE on all sides.

Power Supply Wiring.

- (1) A readily accessible disconnect device and a 1A, 250Vac overcurrent device, must be in the power supply wiring.
- (2) For power supply, connect Phase (or +Ve) to terminal 82, Neutral (or -Ve) to 81, and Earth to 80. To ensure compliance to CE Safety requirements, the grey terminal insulator must be fitted to ALL mains terminals after wiring is completed. (i.e. terminals 82, 81 and 80.) For Non Hazardous Voltage power supplies (not exceeding 42.4Vpeak or 60Vdc) terminals 81 and 80 may be linked together, instead of connecting an earth.

Analogue Signal Wiring.

- (1) All signal cables should be good quality overall screened INSTRUMENTATION CABLE with the screen earthed at one end only.
- (2) Signal cables should be laid a minimum distance of 300mm from any power cables.
- (3) For 2 wire current loops, 2 wire voltage signals or 2 wire current signals, Austral Standard Cables B5102ES is recommended. For 3 wire transmitters and RTDs Austral Standard Cables B5103ES is recommended.
- (4) For differential 2-wire RTD measurement it is important to use identical cables and keep them the same length, so errors due to cable length are kept minimal.
- (5) It is recommended that you do not ground analogue signals and use power supplies with ungrounded outputs.
- (6) Lightning arrestors should be used when there is a danger from this source.
- (7) Refer to diagrams for connection information.

Potentiometers and Resistance

- (1) Use only good quality, sealed, accurate Potentiometers and Resistance Sensors. Check that the operating temperature, mechanical and electrical loading, specifications, rotational life etc meet the application.
- (2) Use Potentiometers and Resistance sensors with better than 5% resistance tolerance and less than 100ppm/C FSO temperature drift. Note the minimum Potentiometer resistance for XJ4 is 1K Ω .

RTDs.

- (1) Avoid locating the RTD where it will be in a direct flame.
- (2) Locate it where the average temperature will be measured. It should be representative of the mass.
- (3) Immerse the RTD far enough so that the measuring point is entirely in the temperature to be measured; nine to ten times the diameter of the protection tube is recommended. Heat that is conducted away from the measuring point causes an error in reading.

Thermocouples.

- (1) Avoid locating the thermocouple where it will be in a direct flame.
- (2) Never insert a porcelain or refractory tube suddenly in a hot area. Pre-heat gradually while installing.
- (3) Locate it where the average temperature will be measured. It should be representative of the mass. If necessary use several thermocouples to obtain the average temperature.
- (4) Immerse the thermocouple far enough so that the measuring junction is entirely in the temperature to be measured: nine to ten times the diameter of the protection tube is recommended. Heat conducted away from the junction causes an error in reading.
- (5) If the thermocouple is mounted horizontally and the temperature is above the softening point of the tube, a support should be provided to prevent the tube sagging. Otherwise install the tube vertically.
- (6) Keep the junction head and cold junction in the approximation of the ambient temperature. Especially in the Noble Metal Class.

Thermocouple Extension Wire.

- (1) Use the correct thermocouple extension or compensation wire. ie Thermocouple type, insulation type, colour coding.
- (2) It is recommended to install extension or compensation cable in a grounded conduit by themselves, or use overall screened cable with the screen earthed at one end only. Never run electrical wires in the same conduit.
- (3) All wires that must be spliced should be soldered, or a proper thermocouple termination block used.
- (4) Lightning arrestors should be used if there is a danger from this source.

XJ4 Commissioning.

- (1) Check that the XJ4 has been set up to the correct input ranges, output ranges and functions. Check it's new calibration and all functions such as Upscale/Downscale Drive and CJC etc. Only use certified calibration equipment. For Thermocouple calibration place the XJ4 and calibration equipment directly next to each other, in still air, with no direct sunshine. Allow both CJC junctions to equalise in temperature before commencing calibration. Lower temperature ranges are affected more by the CJC Junction (allow more time to equalise).
- (2) Once the above conditions have been met, and the wiring checked, apply power to the XJ4, and associated current loops, transducers, sensors and indicators etc. Allow a 5 minute warm-up period - longer for thermocouples - refer following.
- (3) **All Inputs. Examples of Calibration.**
 - (a) Take a low reading of the variable being measured by the transducer supplying the signal to the XJ4 and adjust the Zero Pot in the top of the XJ4 enclosure until the correct reading is achieved on the PLC or indicator, etc, that the XJ4 is connected into.
 - (b) Take a high reading of the variable being measured by the transducer supplying the signal to the XJ4 and adjust the Span Pot in the top of the XJ4 enclosure until the correct reading is achieved on the PLC or indicator, etc, that the XJ4 is connected into.
 - (c) Repeat (a) and (b) until the desired accuracy is achieved.
 - Note 1. Turn the Pot with a small screwdriver. Clockwise to increase the output reading and anti-clockwise to decrease the output reading.
 - Note 2. For RTD and Thermocouple inputs that have previously been calibrated using certified calibration equipment only a Zero Pot adjustment is required. Refer below.

Bridge / Strainage Inputs; (a) Low reading suggest no load on the load cell. (b) High Reading suggest with certified calibration weights on the load cell. Note the 10Vdc, Voltage and Temperature stable Bridge Supply, is $\pm 3\%$ accurate typical. This error will be calibrated out in the above procedure. The 10V Bridge Supply can take a maximum load of 30mA or a load cell with a resistance of 340 Ω . or greater. If more than 1 load cell is required a seperate precision 10Vdc supply must be used.

DC Voltage and Current Input; (a) Low reading suggest approx 10%, (b) High reading suggest approx 90% of the variable being measured by the transducer supplying the signal to the XJ4. Max. load on the 20Vdc P/S is 30mA.

Potentiometer Inputs; Due to cable resistance and errors within the potentiometer itself an error may occur (Usually less than 5%). (a) Low reading suggest move Potentiometer to 0% of its range. (b) High reading suggest move potentiometer to 100% of its range

Resistance Input; Errors can occur due to differences in cable resistance in the Resistance legs, and errors in the Resistance itself. (Usually less than 5%. Pot used as a Resistance, error can be 25%). (a) Low reading suggest move Resistance to 0% of its range. (b) High reading suggest move Resistance to 100% of its range.

RTD Inputs; A small error can occur due to differences in cable resistance in the RTD legs, and errors in the RTD itself. (Usually less than 0.5C). Place all the RTD probes into a calibrated thermal bath at the temperature interest or use a calibration standard RTD at the same immersion depth and temperature of interest and adjust the Zero Pot until the two temperatures agree.

RTD Differential Input; For differential 2-wire RTD measurement it is important to use identical cables and keep them the same length, so errors due to cable length are kept minimal. Refer RTD Input above to zero out zero offset errors due to mismatch between the two 2-wire RTD's.

Thermocouple Inputs; Due to the limits of error in a standard thermocouple probe, and standard extension wire and compensating wire, an error can occur. Eg. In a type K thermocouple installation an error of 2.2C or 0.75% FSO can occur (whichever is greater). For low temperature thermocouple measurement, the enclosure must be assembled and avoid drafts and temperature differences across terminals. Once installation is complete, close the cabinet door and allow the cabinet to reach equilibrium. This may take several hours. Place the thermocouple probes into a calibrated thermal bath at the temperature of interest or use a calibration standard thermocouple at the same immersion depth and temperature of interest and adjust the Zero Pot until the two temperatures agree.

XJ4 Maintenance.

Bridge / Strainage, DC Voltage and Current, Potentiometer and Resistance Inputs.

- (1) Check the Sensor or Transducer supplying the signal to the XJ4 for wear or damage and replace if defective.
- (2) Check the cables connected to the Sensor or Transducer.
- (3) Repeat (3) of commissioning. Do it regularly - at least once every six months.

RTD Inputs.

- (1) Replace defective protection tubes - even if they look good they may not be air or gas tight.
- (2) Check cables entering the RTD sensor head.
- (3) Repeat (3) of commissioning. Do it regularly - at least once every six months.

Thermocouple Inputs.

- (1) Replace defective protection tubes - even if they look good they may not be air or gas tight.
- (2) Check extension and compensating cable circuits, especially cables entering the Thermocouple sensor head.
- (3) Do not use the same chromel-alumel (Type K) thermocouple below 540C if it was used above 860C.
- (4) Repeat (3) of commissioning. Do it regularly - at least once a month.

Intech INSTRUMENTS LTD www.intech.co.nz Christchurch Ph: +64 3 343 0646 Central Ph: 06 876 0034 Auckland Ph: 09 827 1930 Email: sales@intech.co.nz
